

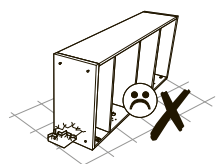

ALDO 06

09.01.2024

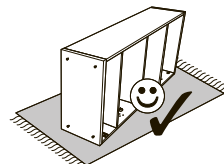

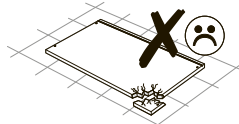
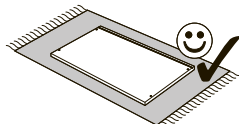
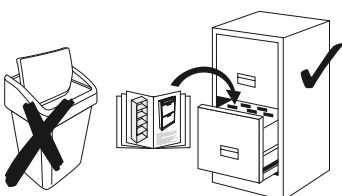
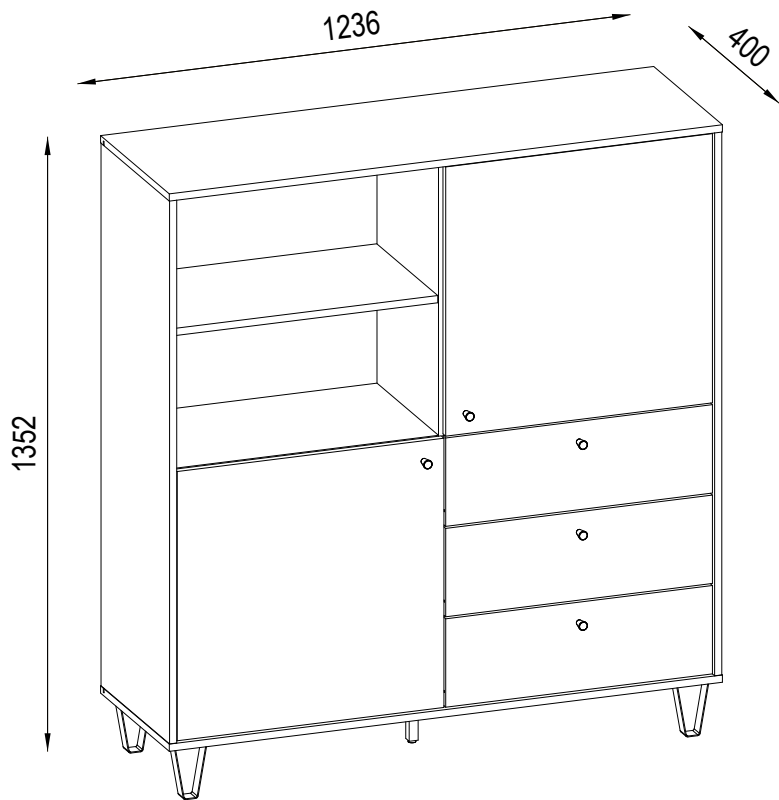
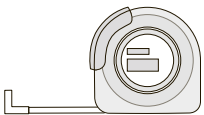
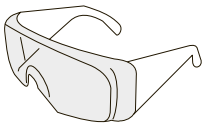
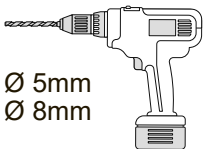
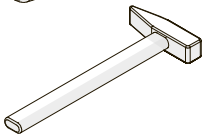
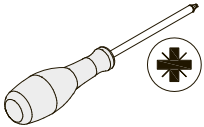
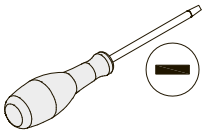
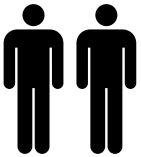
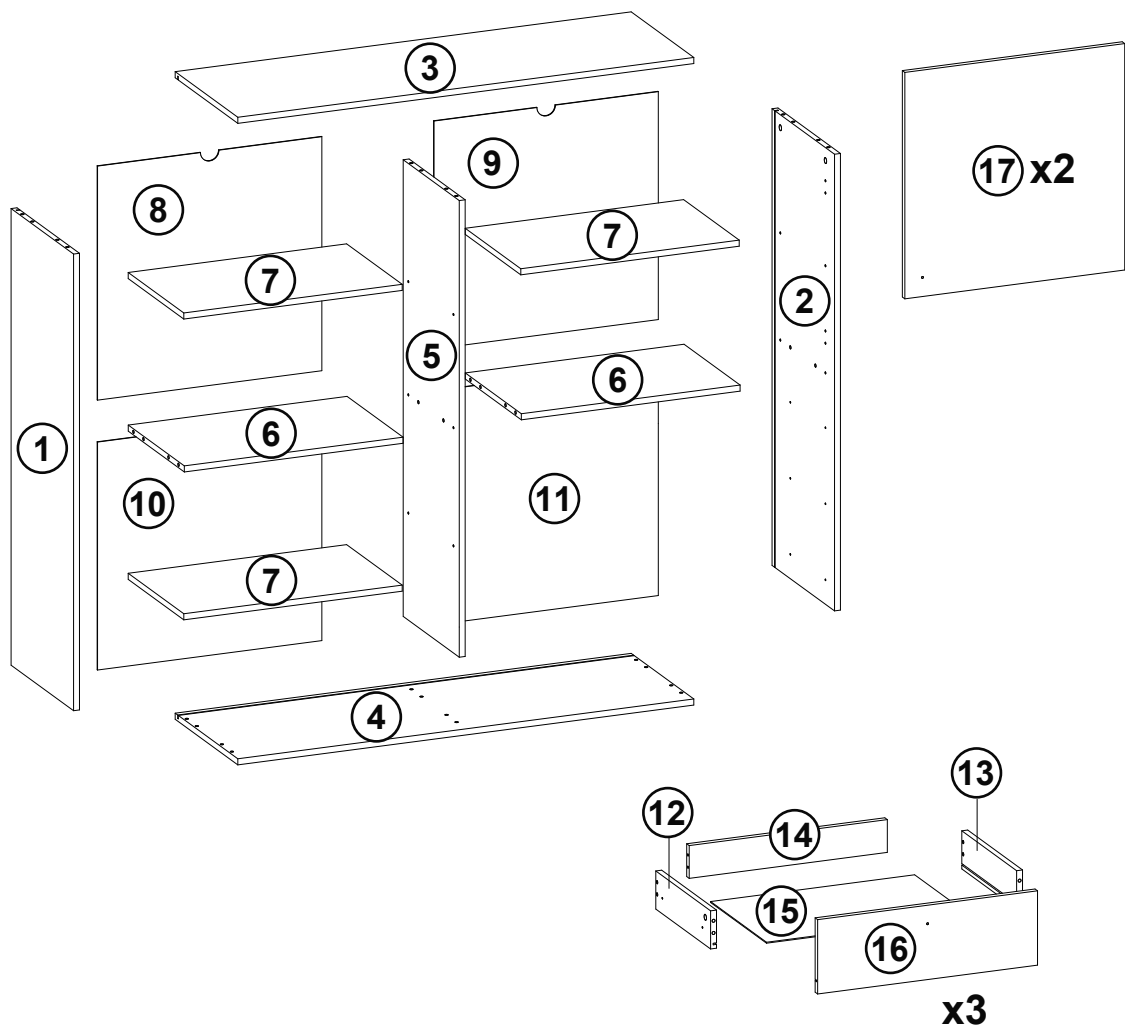



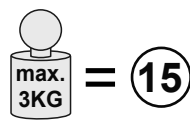



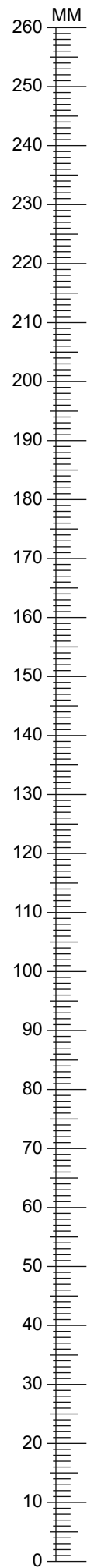
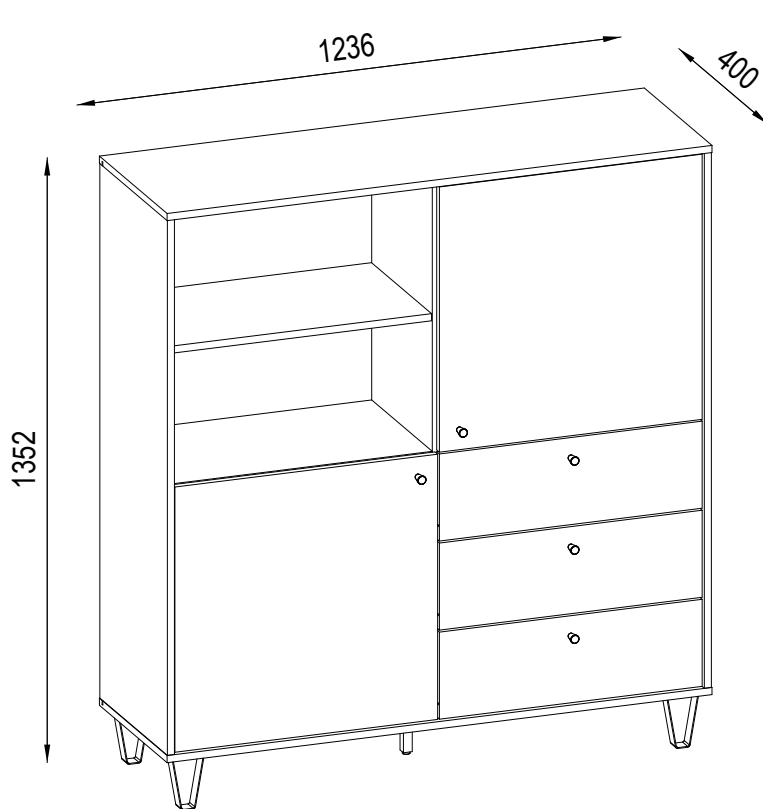

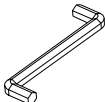
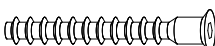

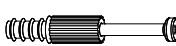

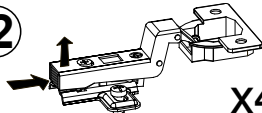
A	B (mm)			C	D
1	1200	399	16	x1	2/3
2	1200	399	16	x1	2/3
3	1236	400	16	x1	2/3
4	1236	400	16	x1	2/3
5	1200	358	16	x1	2/3
6	593	358	16	x2	3/3
7	592	355	16	x3	3/3
8	608	614	2,5	x1	1/3
9	608	598	2,5	x1	1/3
10	608	598	2,5	x1	1/3
11	608	614	2,5	x1	1/3
12	350	100	16	x3	1/3
13	350	100	16	x3	1/3

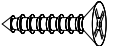
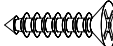

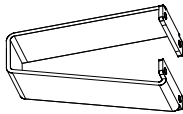
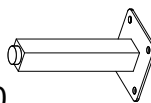
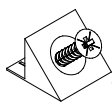
A	B (mm)			C	D
14	537	86	16	x3	1/3
15	553	357	2,5	x3	3/3
16	596	195	16	x3	1/3
17	596	596	16	x2	1/3

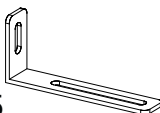
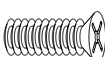

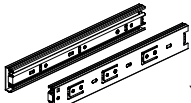
FA1  4mm x1	F3  6,3x50 x18	B2  8x30 x26
A1  15x12 x20	C2  44mm x20	O3  Ø18 x16
K12  Ø35 x4	J60  Ø19 x5	N1  Ø6 x12
D10  3x16 x12	D11  3,5x16 x12	DA21  4,2x16 x32
P14  + 4x16 screws h=120 x4	P6  120x20x20 x1	M1  10x10x15 x19
DB2  4x25 x5	Y36  75x32x15 x2	
E6  5x13 x12	Y37  8x50 x2	Y38  5x50 x2
I5  350 x3		

1

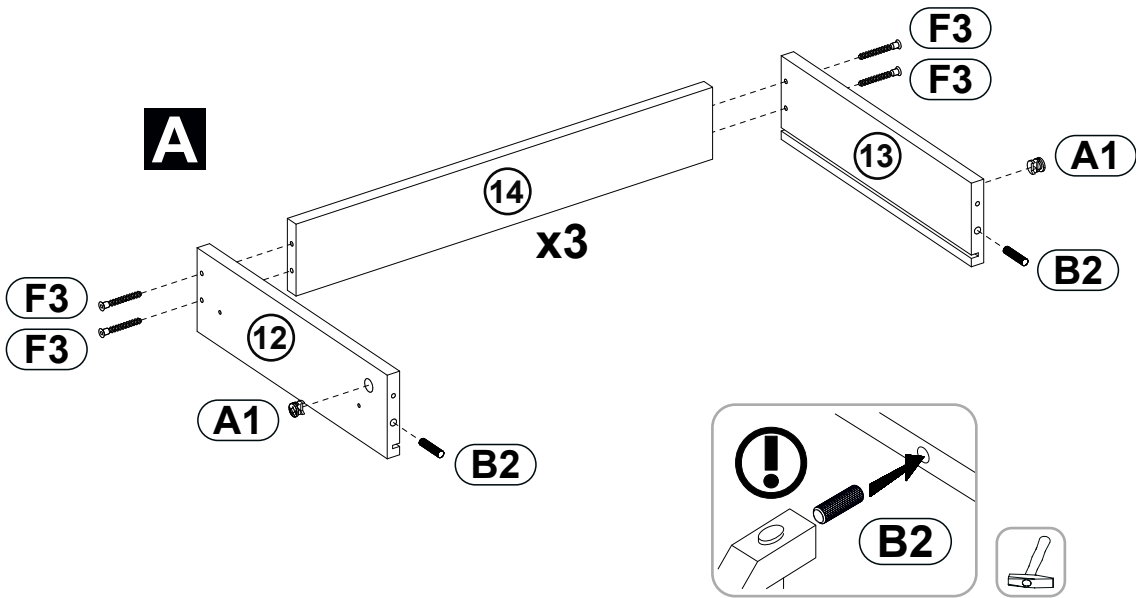
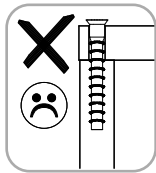
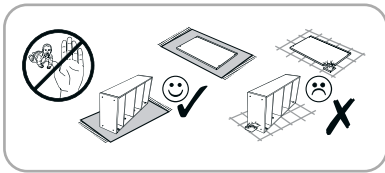

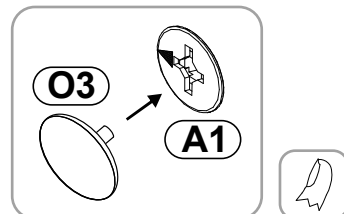
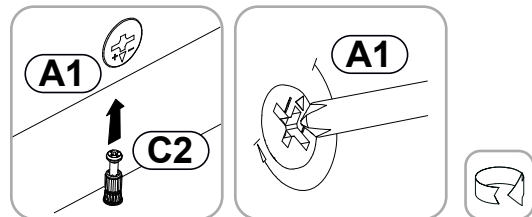
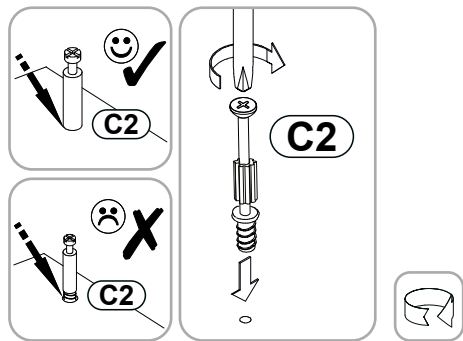
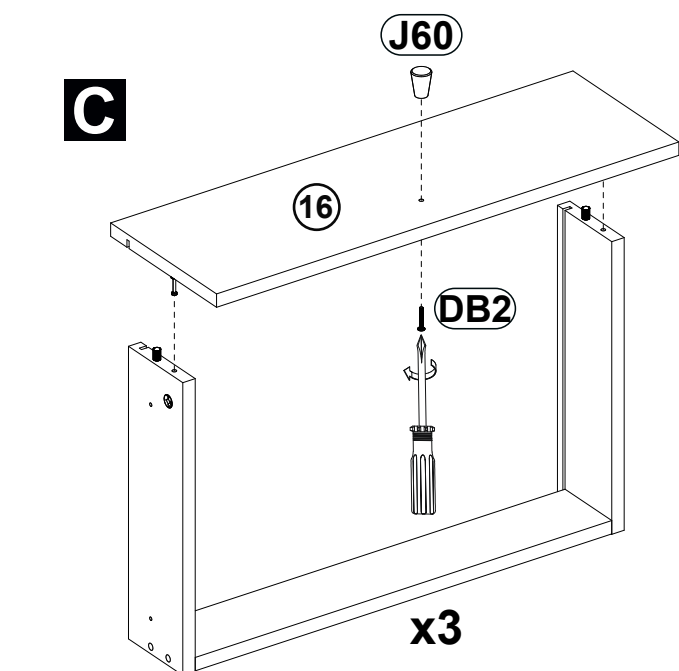
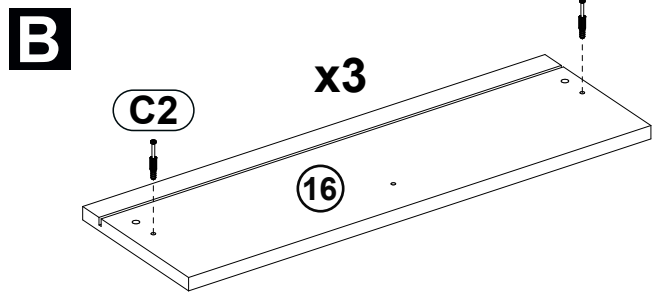
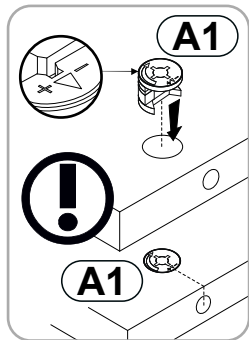
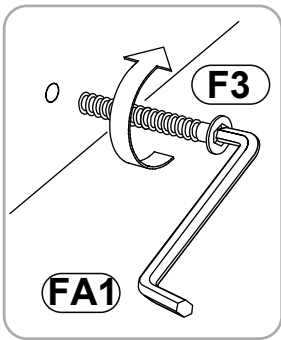

FA1		x1
F3		x12
A1		x6
C2		x6
B2		x6
J60		x3
DB2		x3
O3		x6

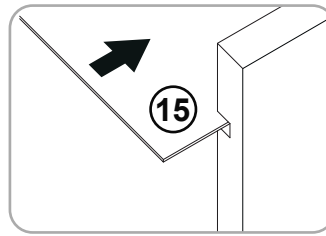
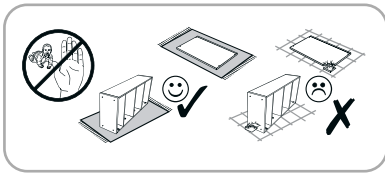

2

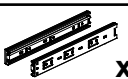

- DA21**
4,2x16  x15
- I5**
350  x3
- D10**
3,0x16  x12
- M1**
10x10x15  x3

D

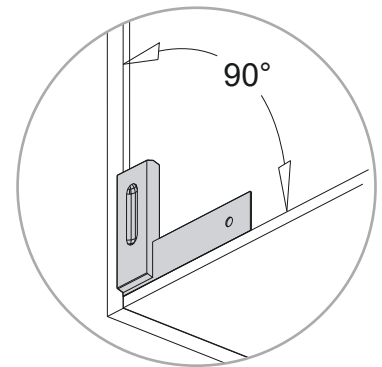
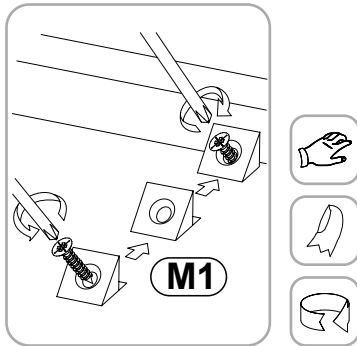
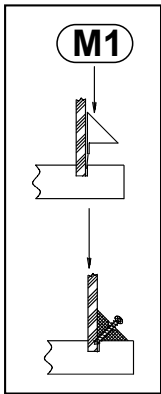
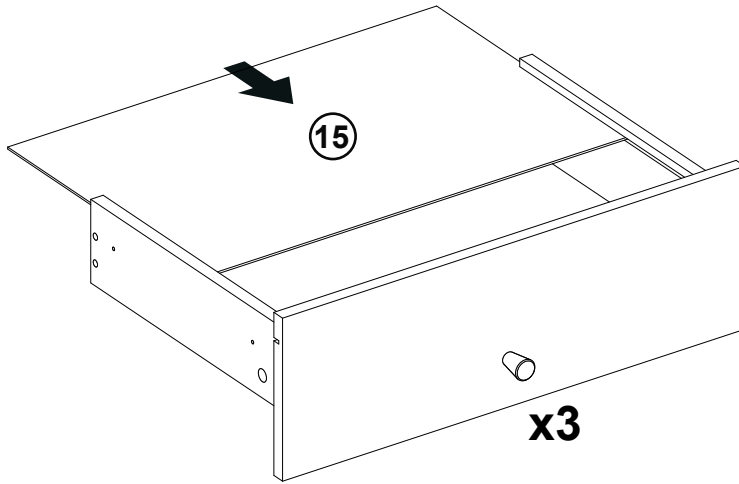





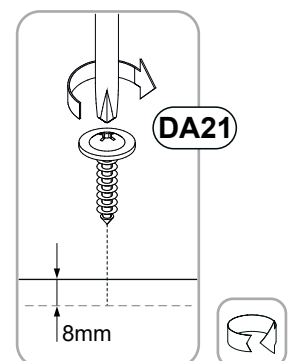
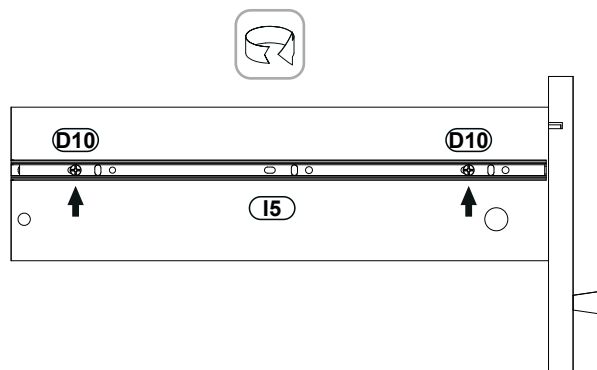
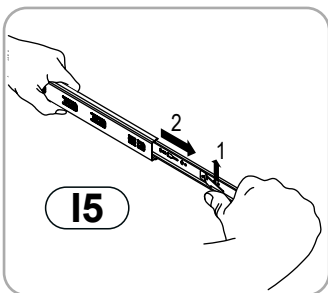
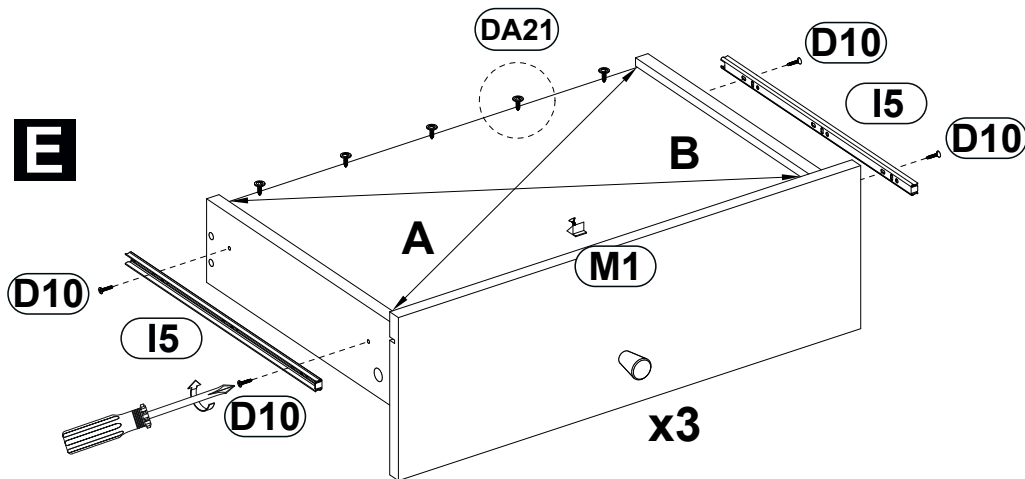

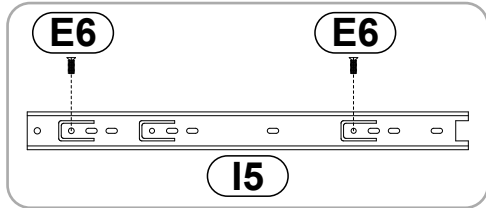
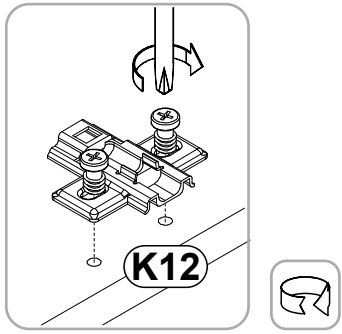
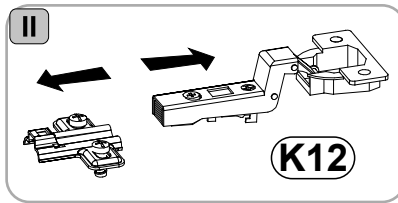
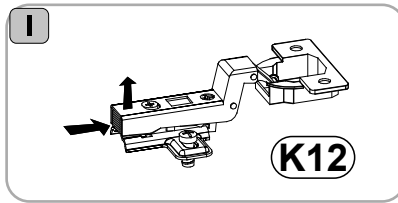
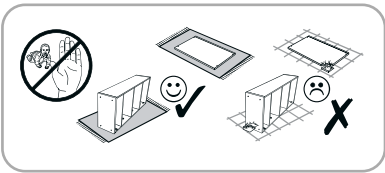

A=B

E

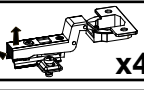

3

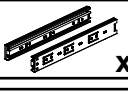

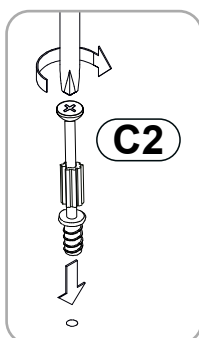
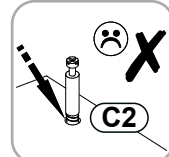
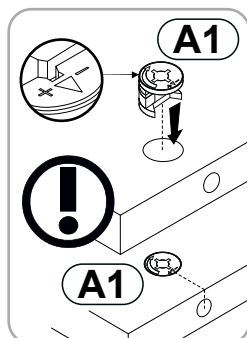
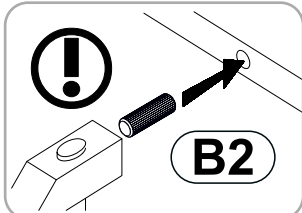
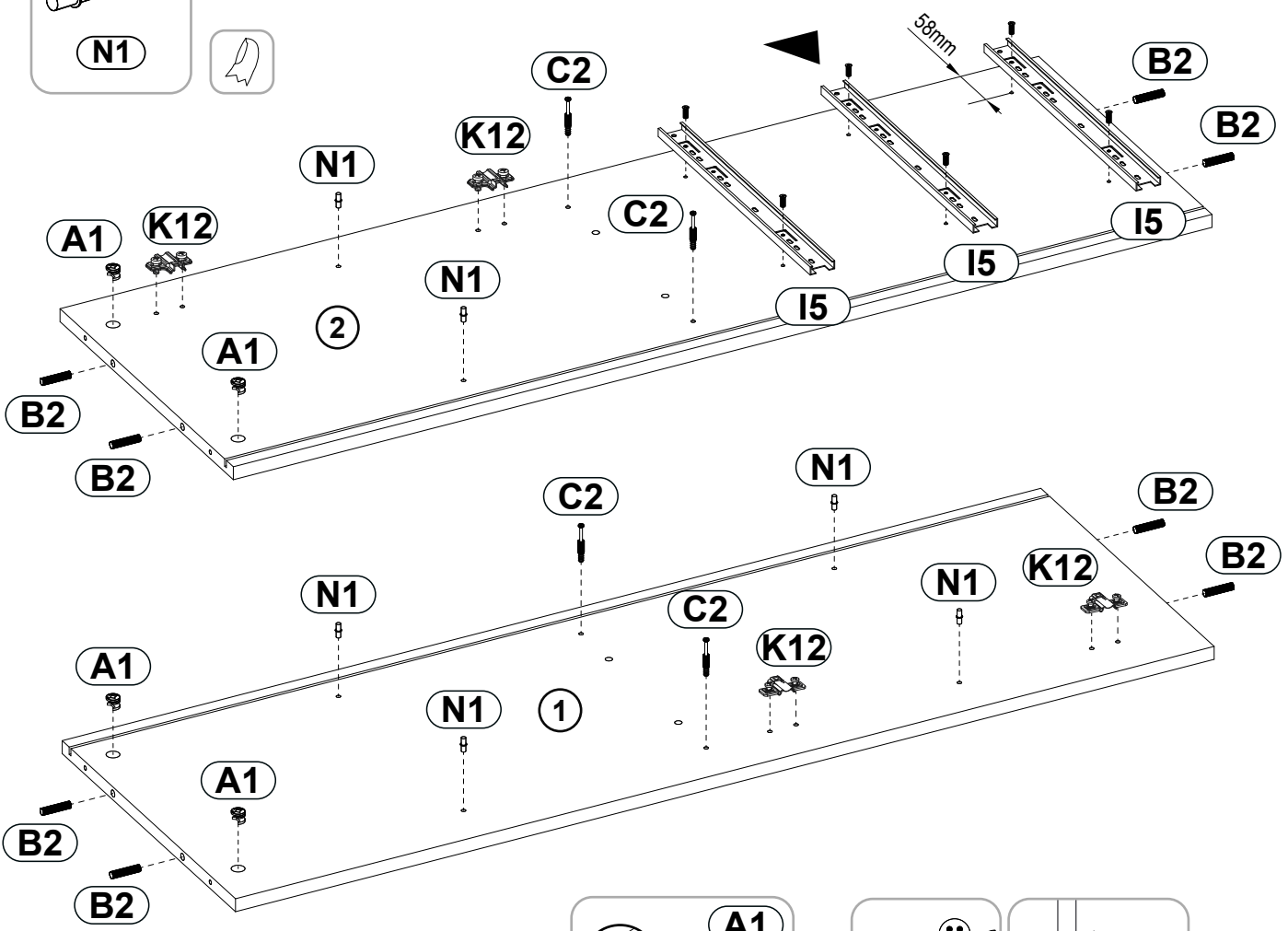
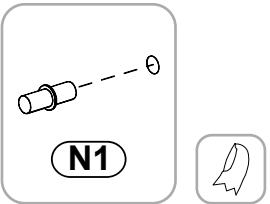

- A1**  **x4**
15x12
- C2**  **x4**
44mm
- B2**  **x8**
8x30
- K12**  **x4**
Ø35
- N1**  **x6**
Ø6
- I5**  **x3**
350
- E6**  **x6**
5x13

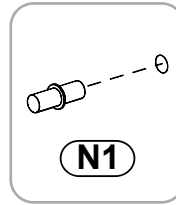
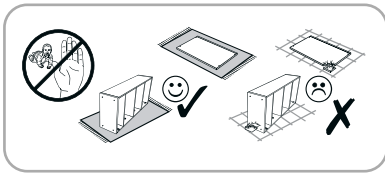

4





A1  **x2**
15x12

C2  **x4**
44mm

B2  **x4**
8x30

N1  **x6**
Ø6

I5  **x3**
350

E6  **x6**
5x13

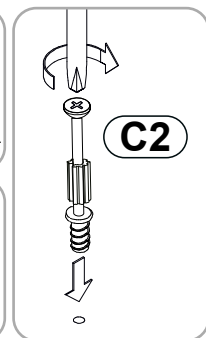
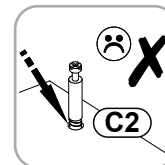
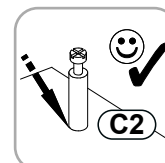
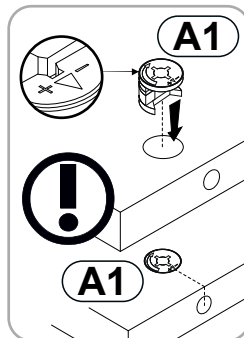
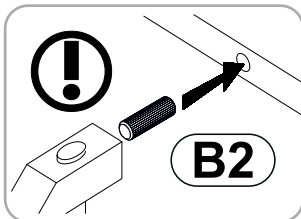
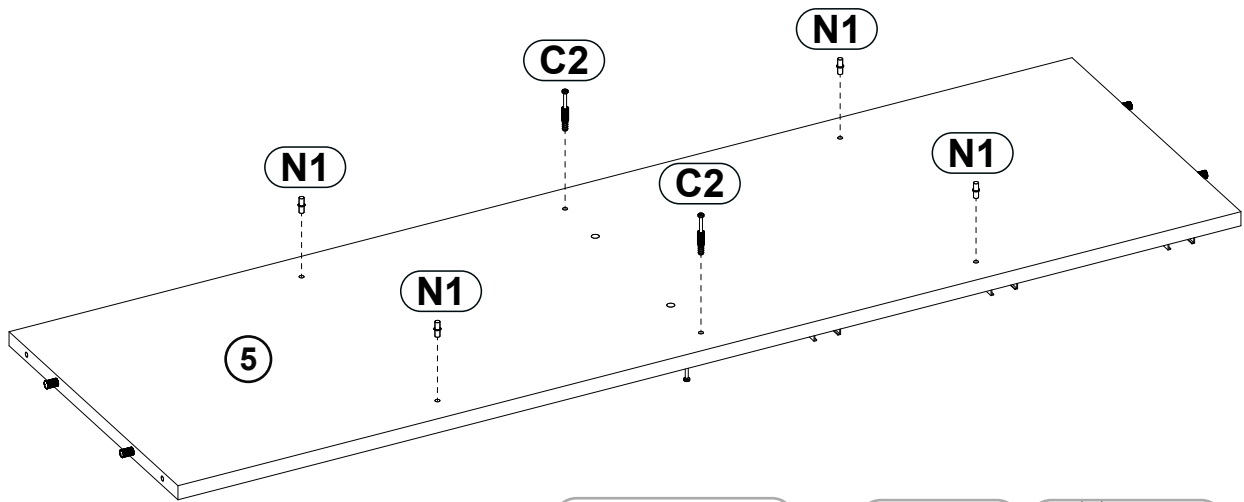
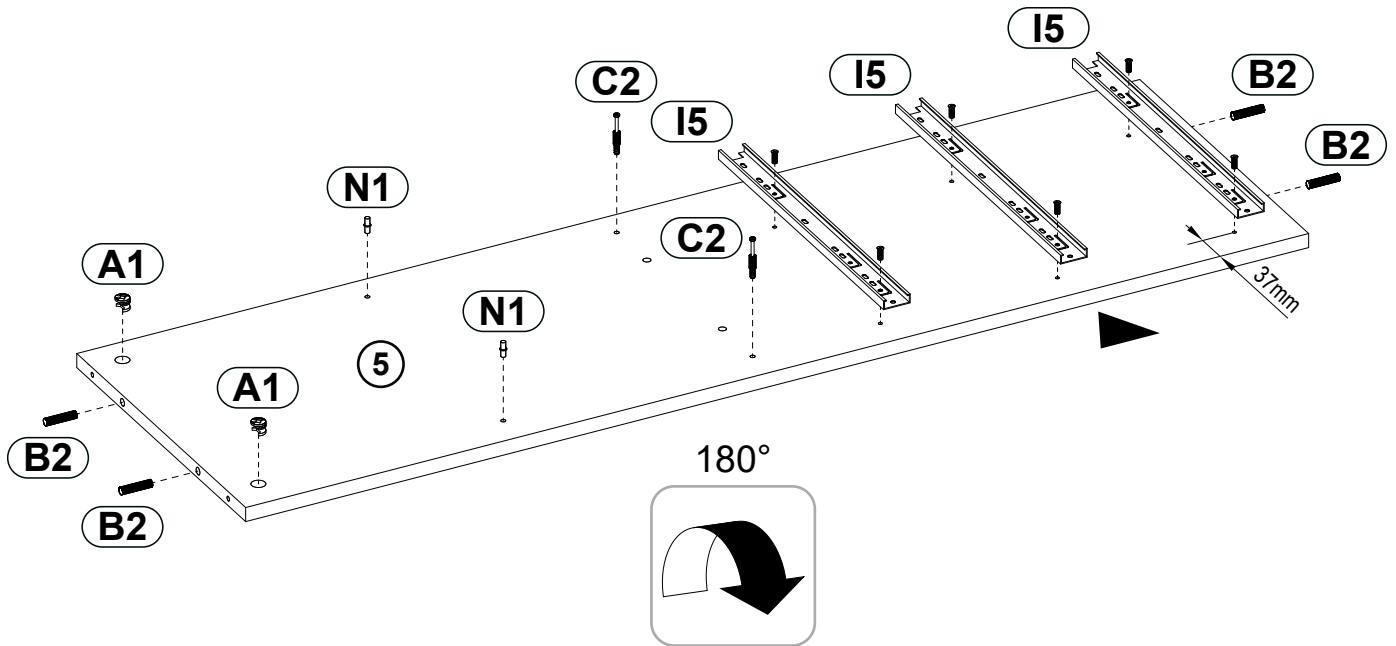
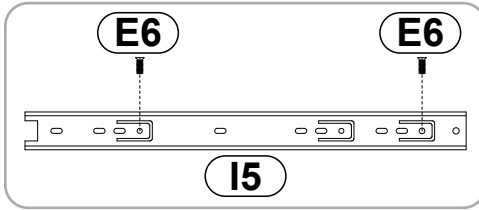

5

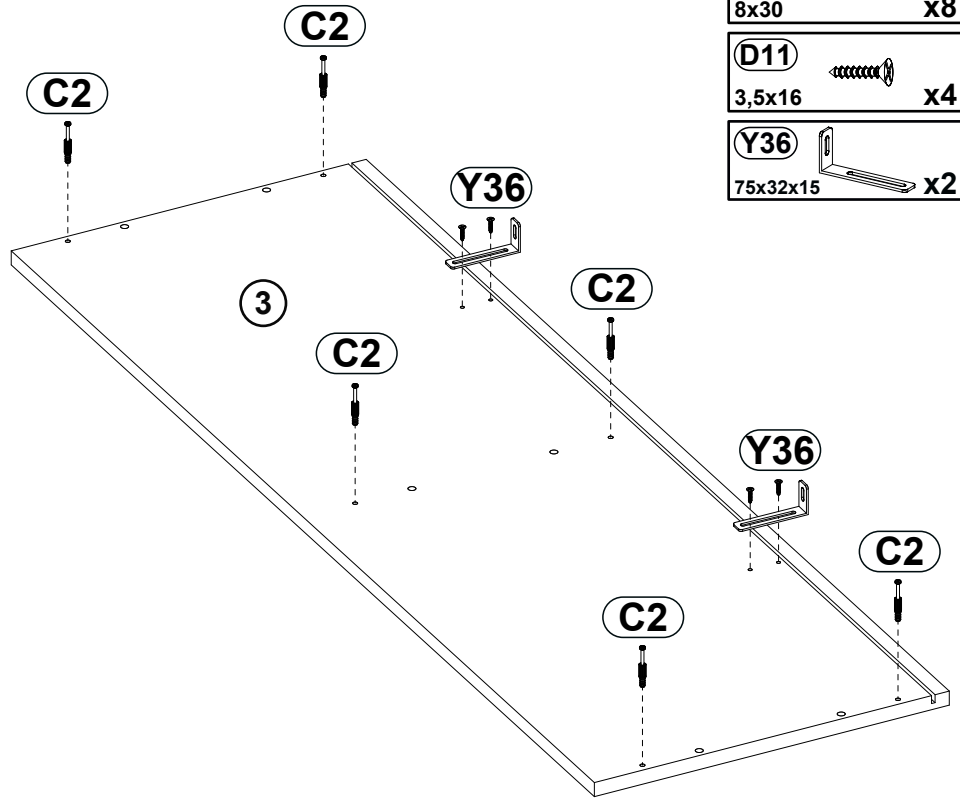
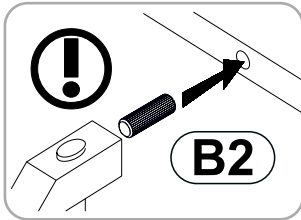
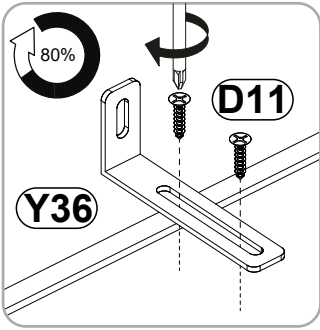
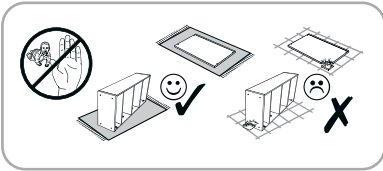

A1  **x8**
15x12

C2  **x6**
44mm

B2  **x8**
8x30

D11  **x4**
3,5x16

Y36  **x2**
75x32x15

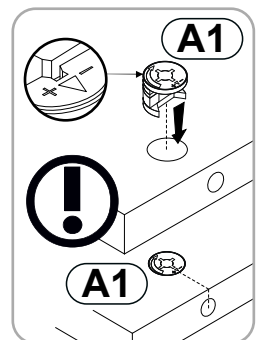
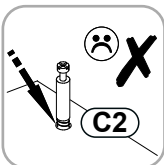
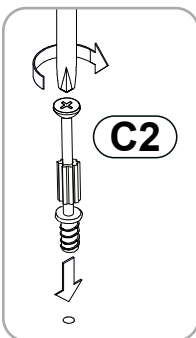
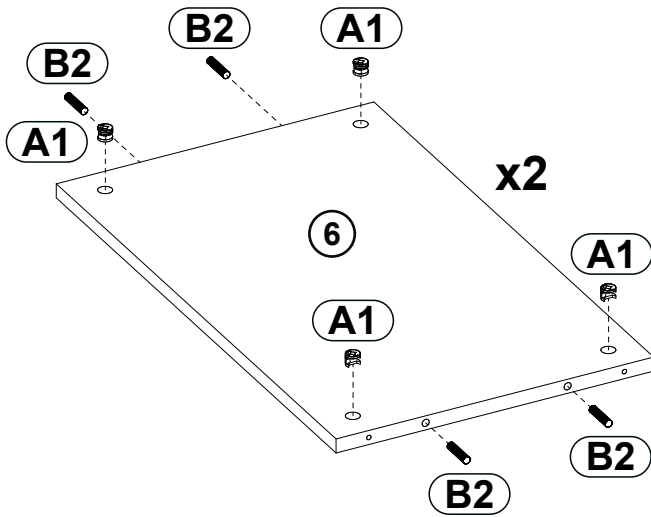

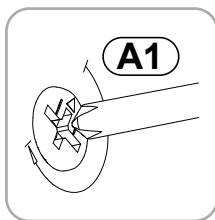
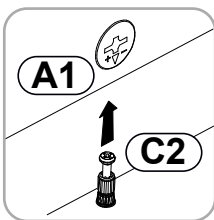
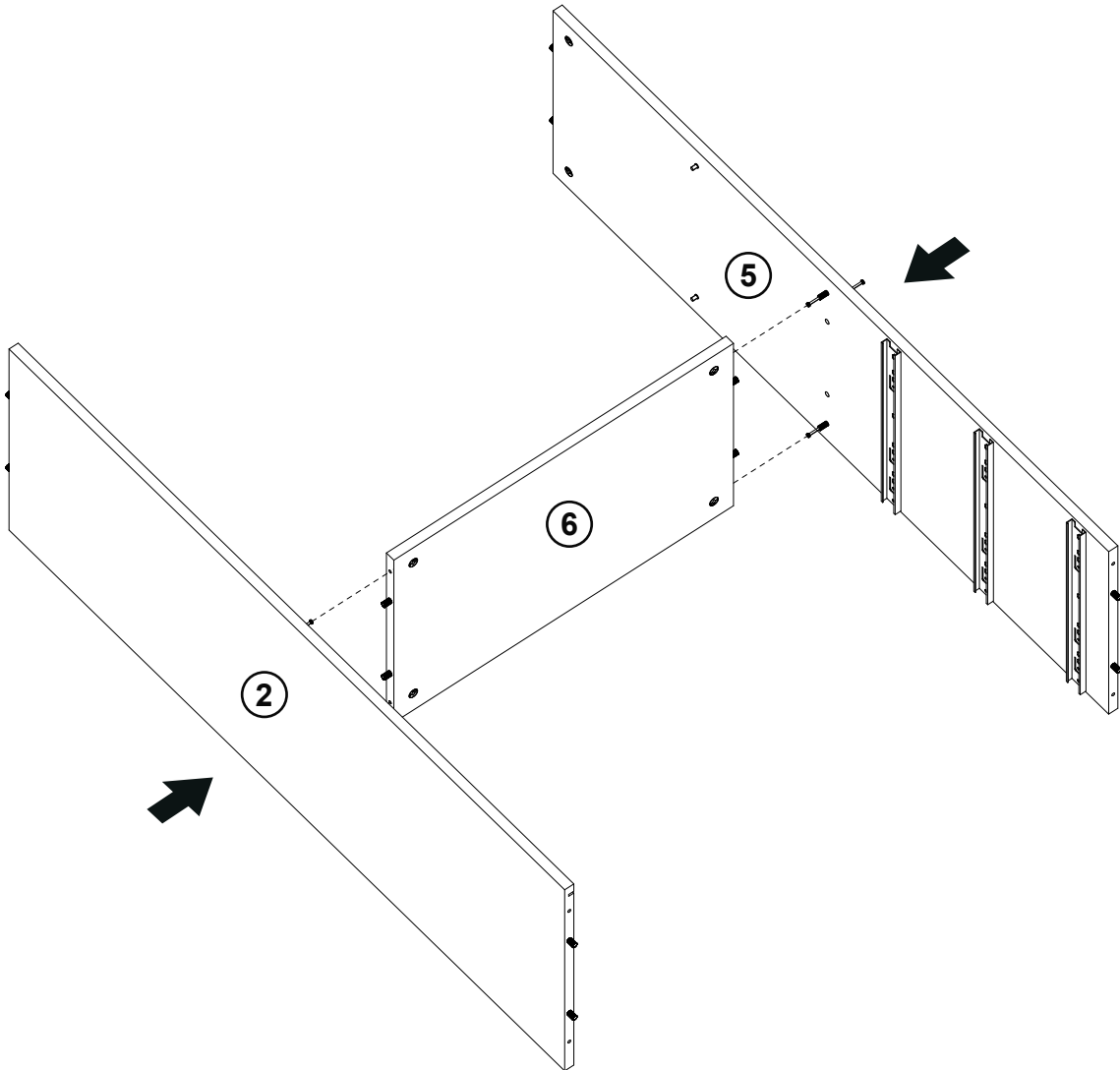
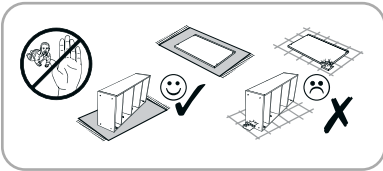

6

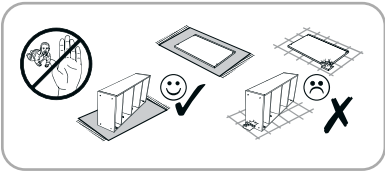

7

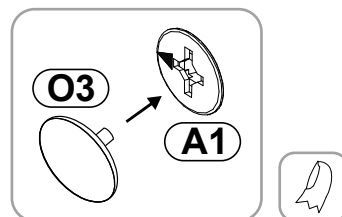
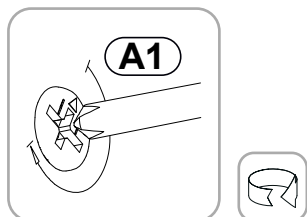
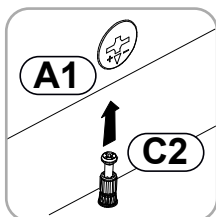
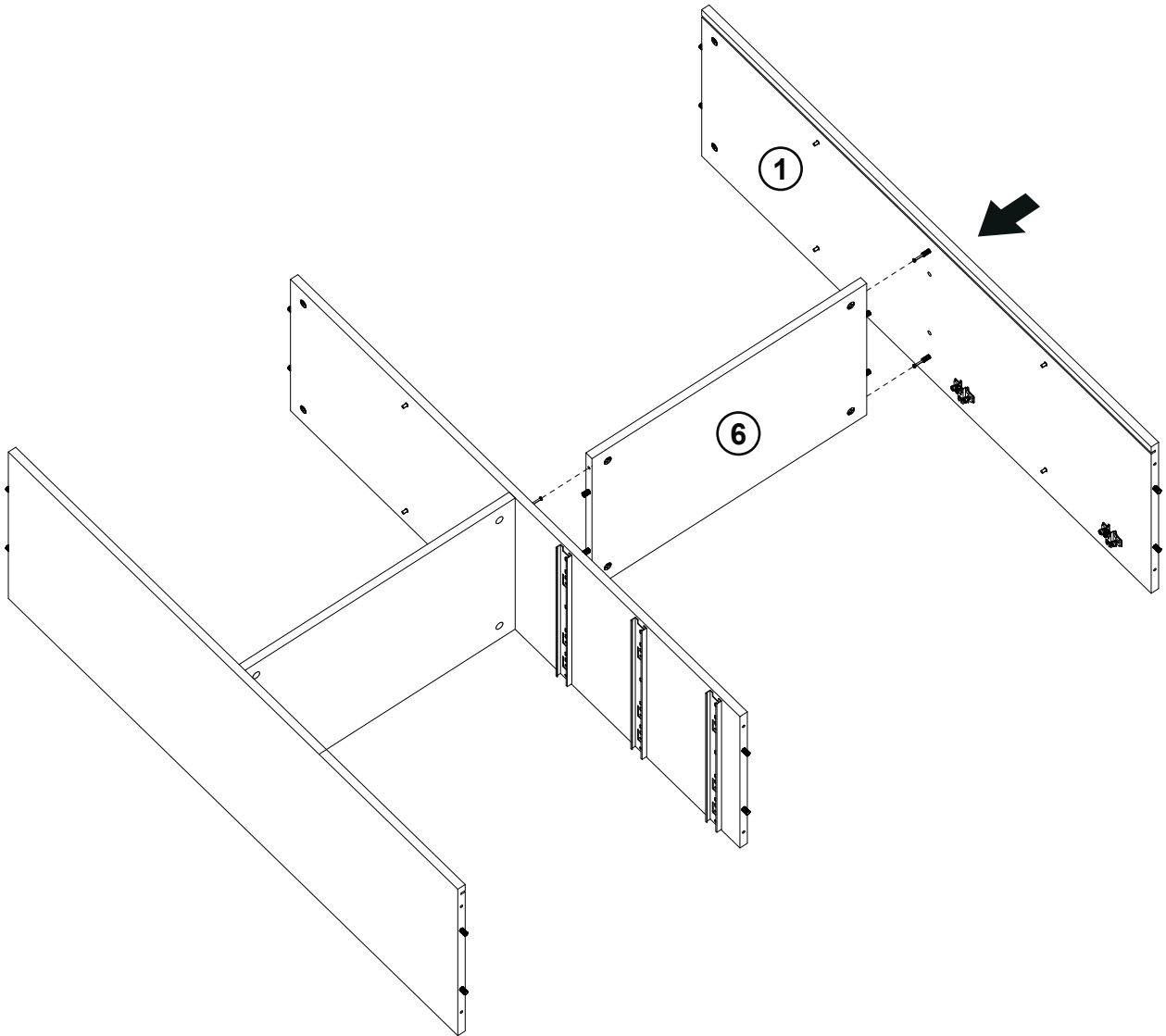

O3
Ø18 x4



8

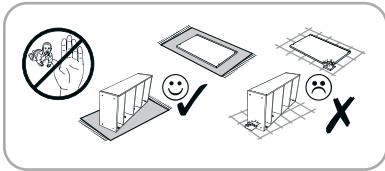

O3
Ø18 x6

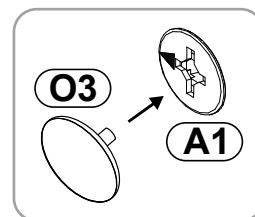
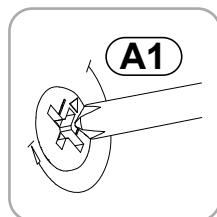
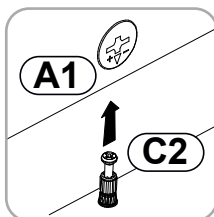
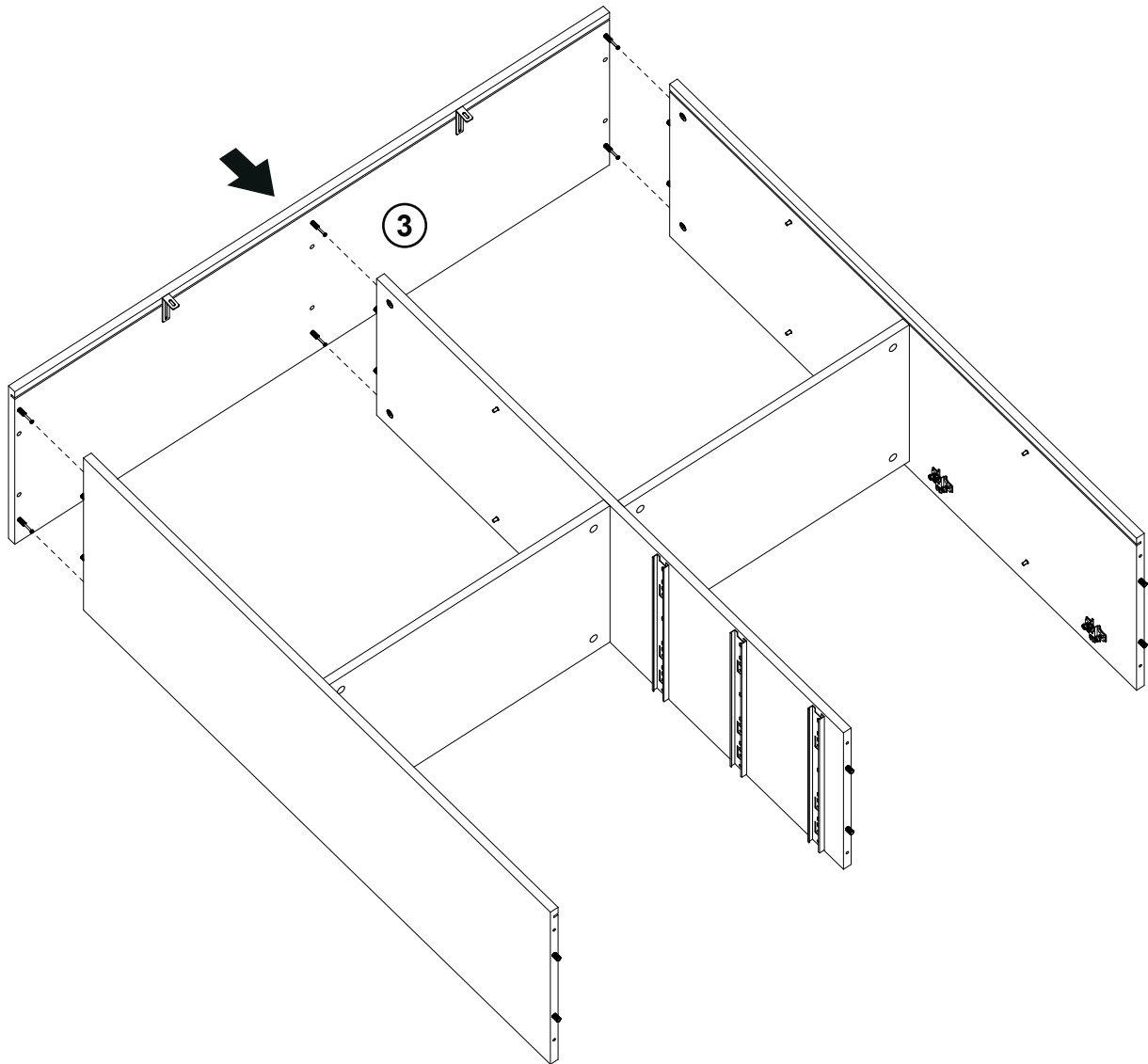

9

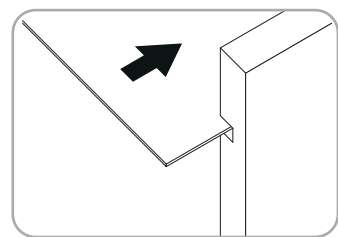
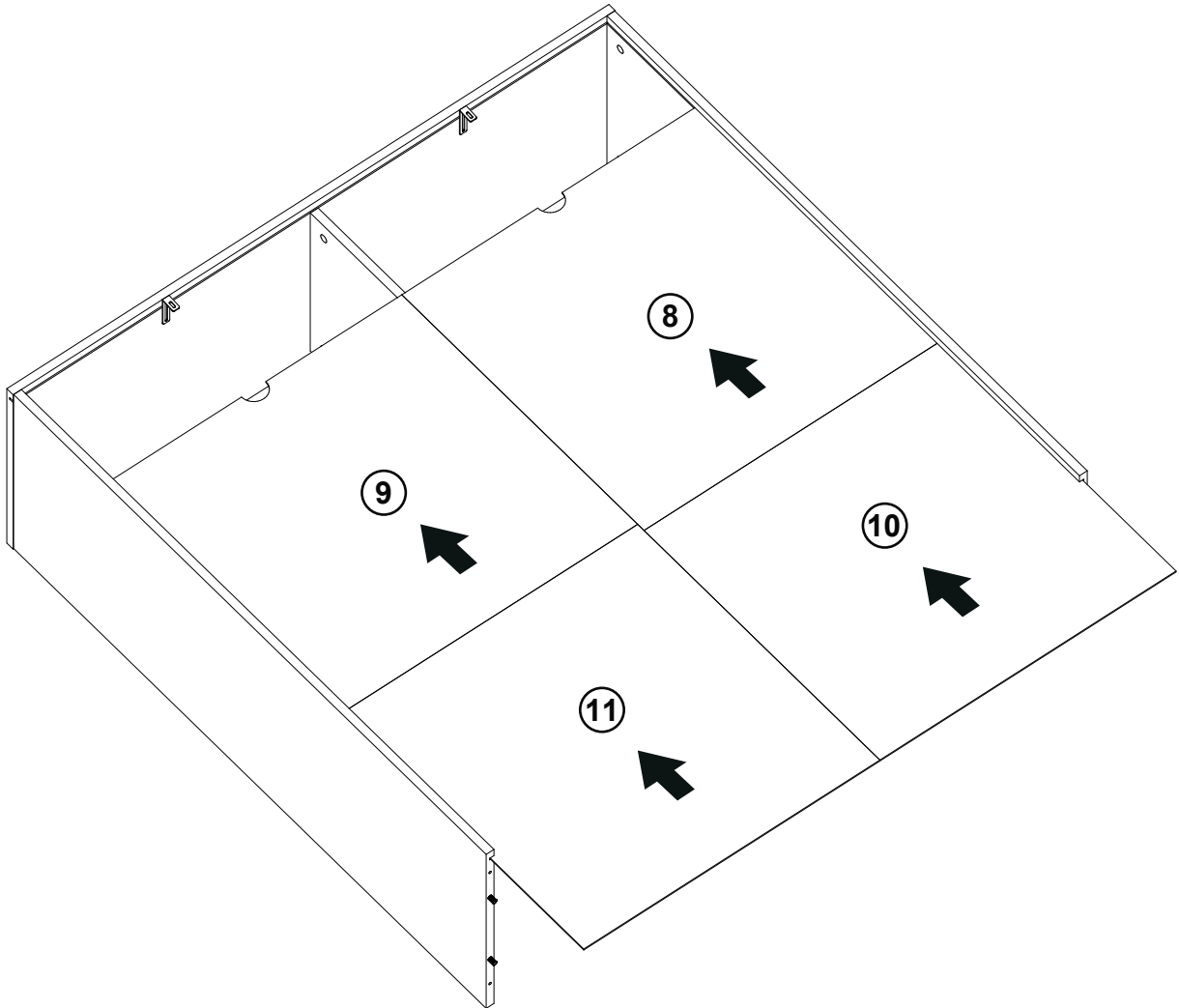
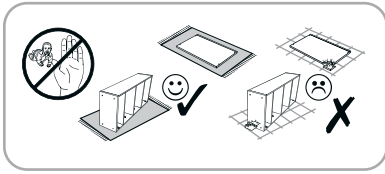

10

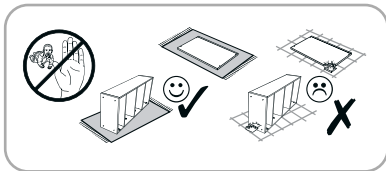

FA1
4mm x1

F3
6,3x50 x6

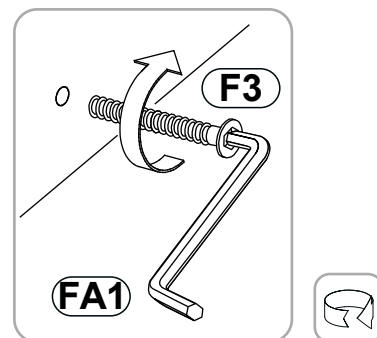
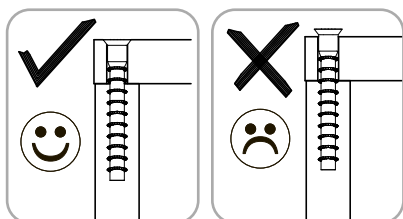
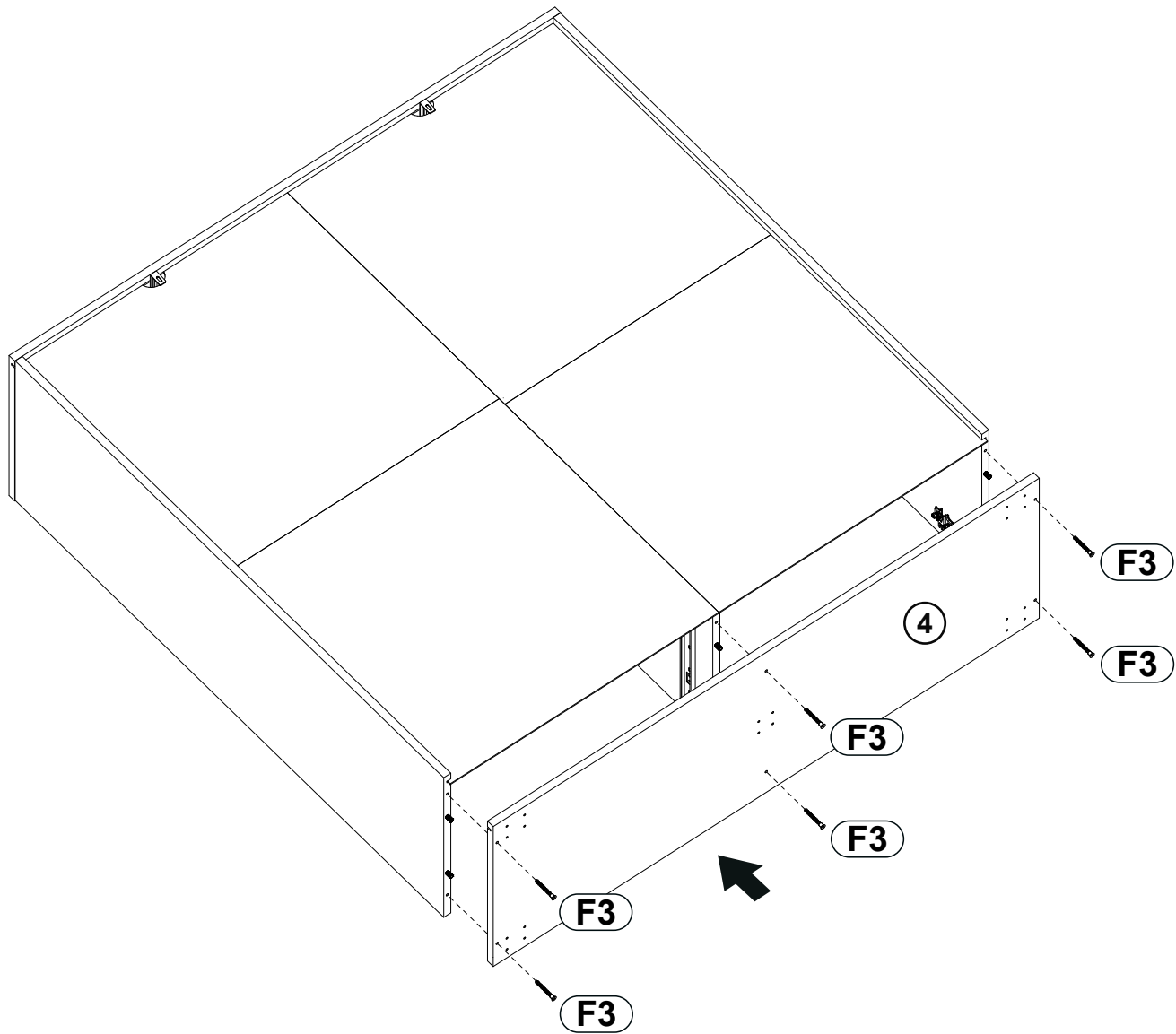

11

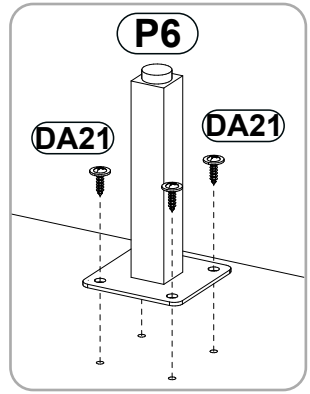
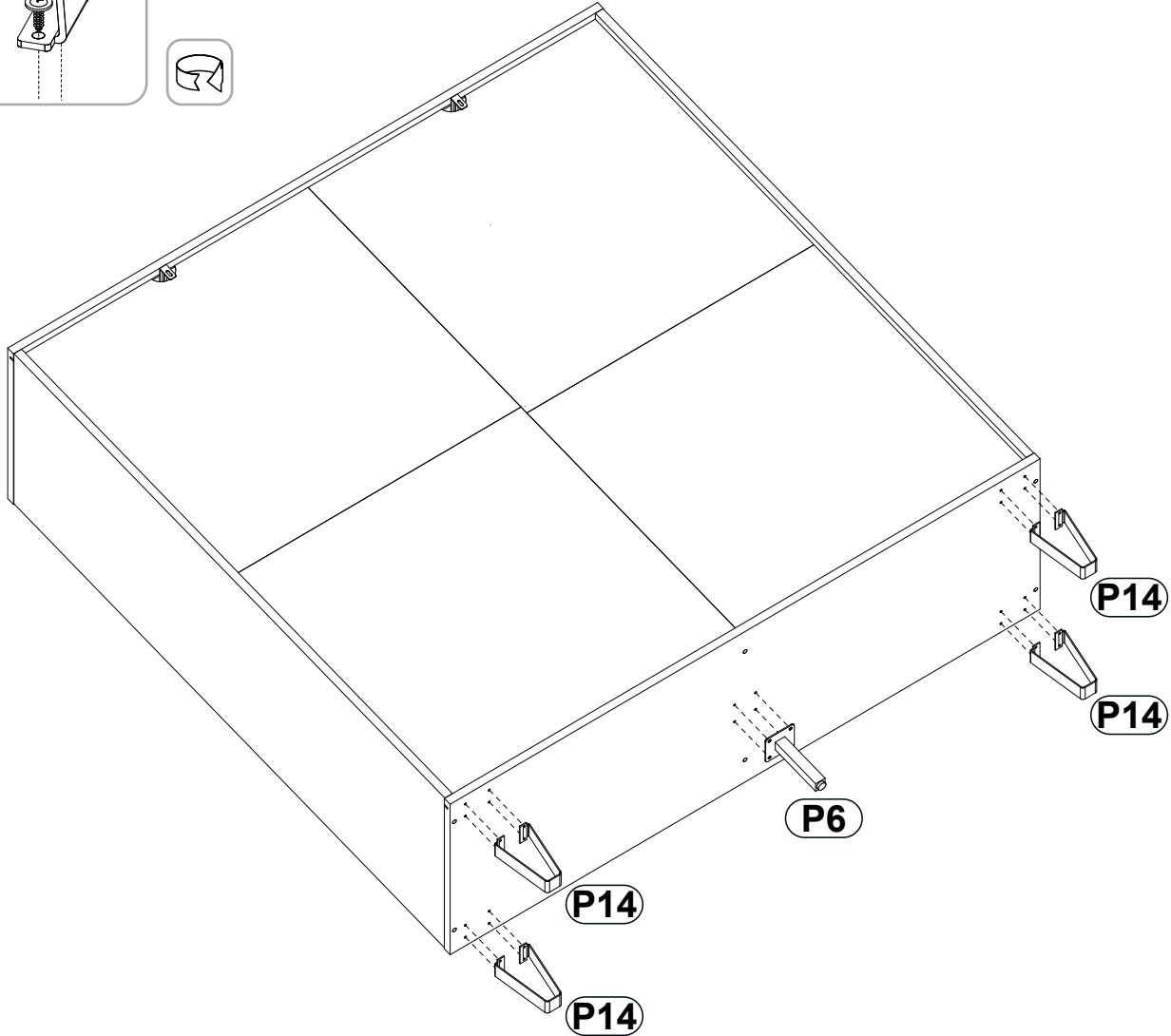
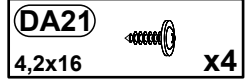
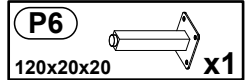
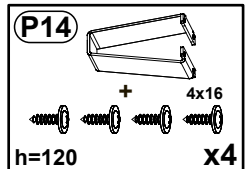
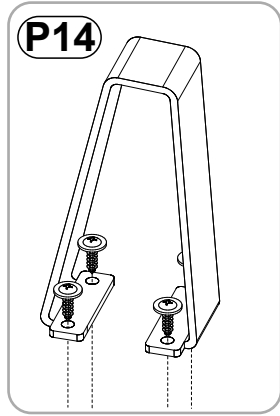
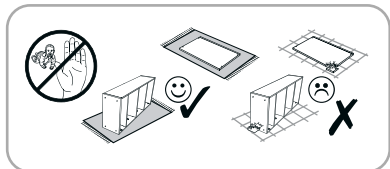

12

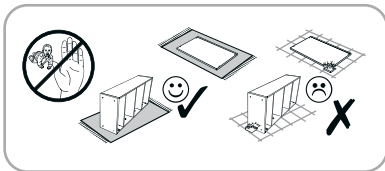

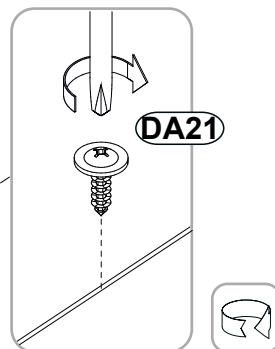
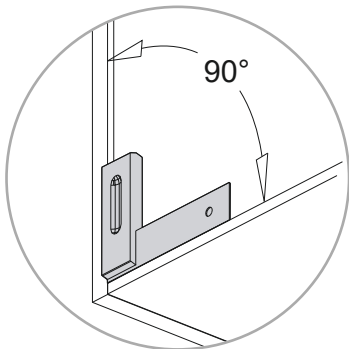

M1
10x10x15 x16

DA21
4,2x16 x13

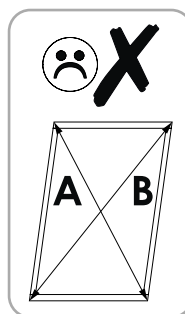
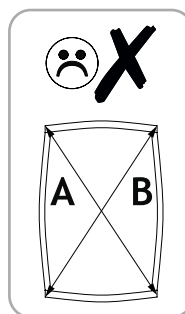
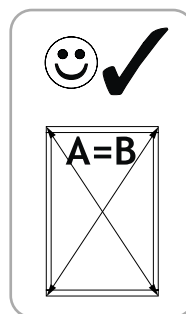
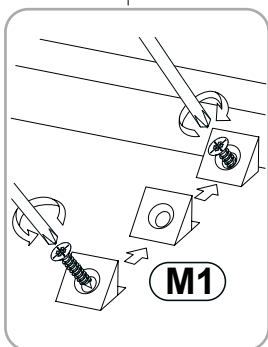
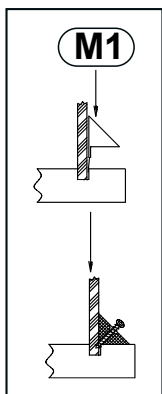
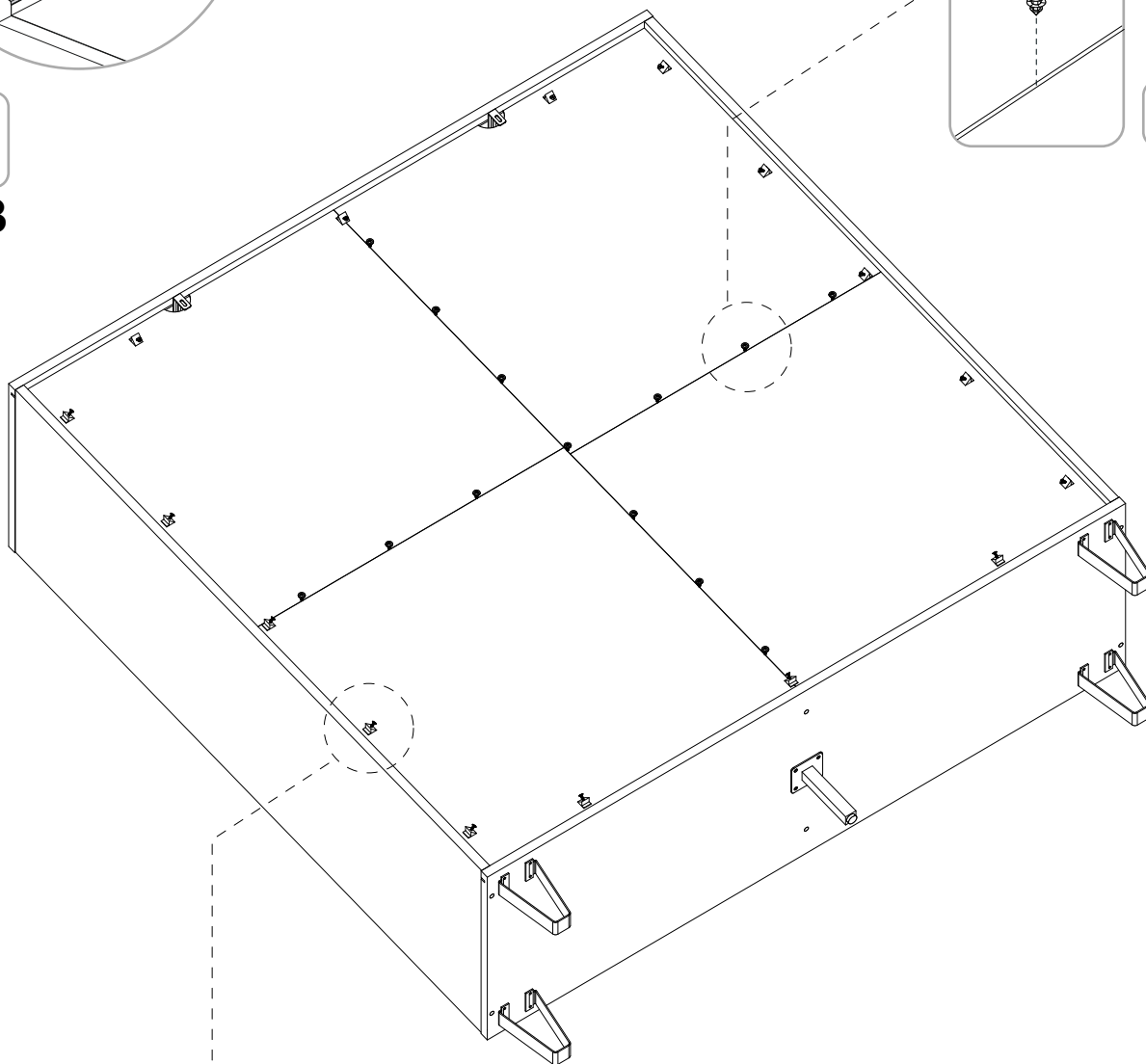

A=B



Y37
8x50  x2

Y38
5x50  x2

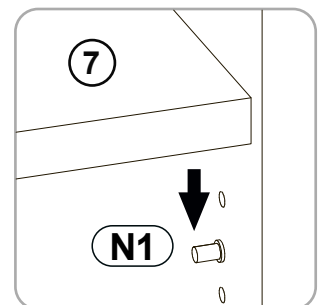
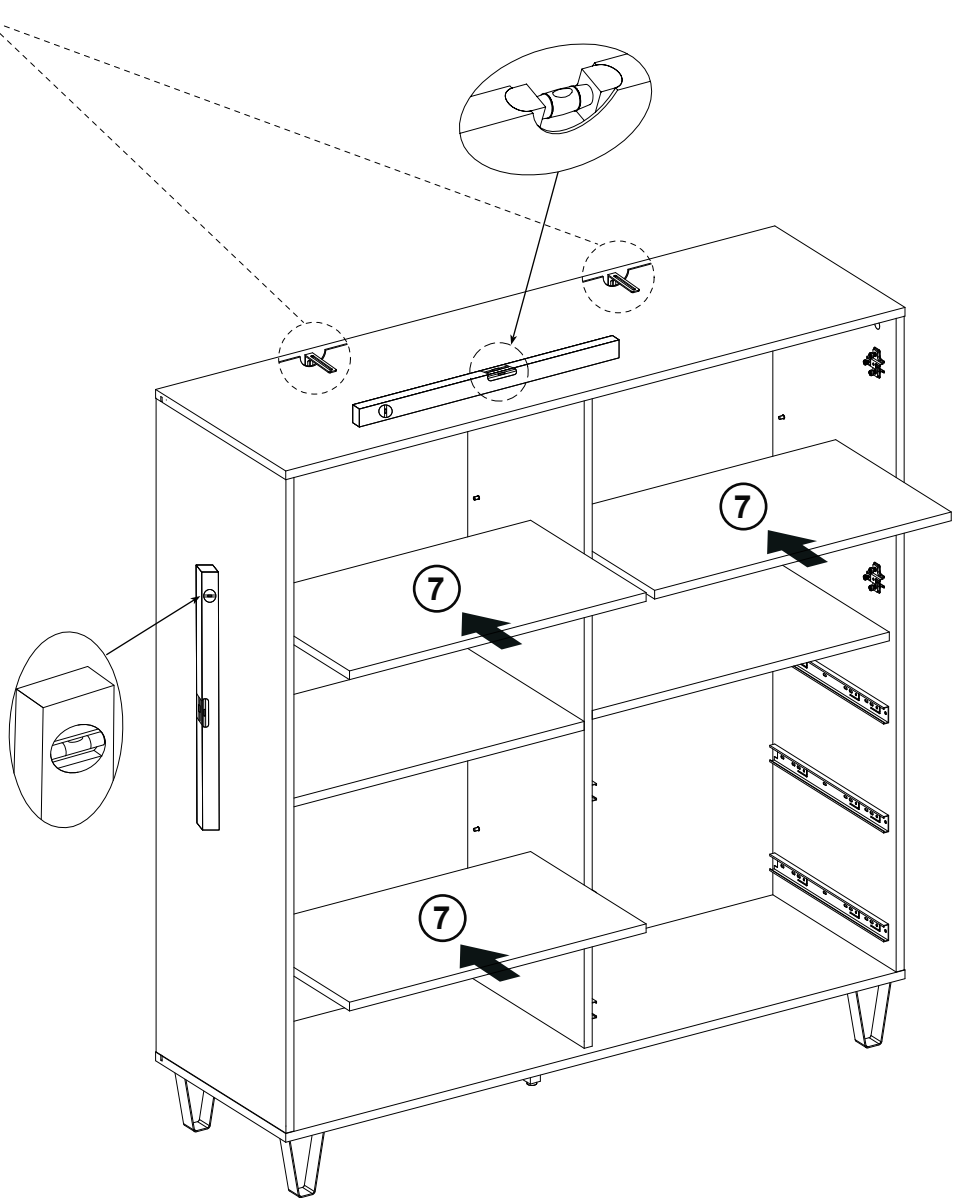
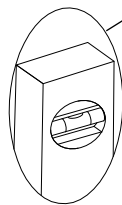
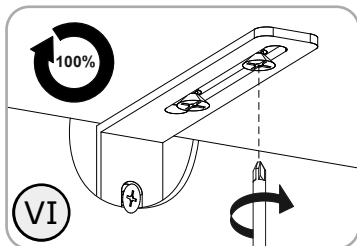
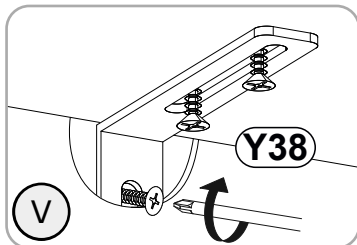
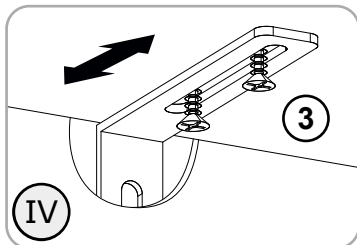
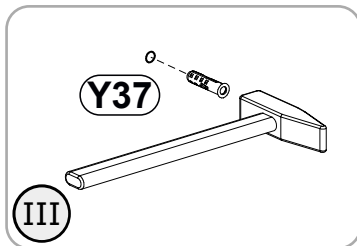
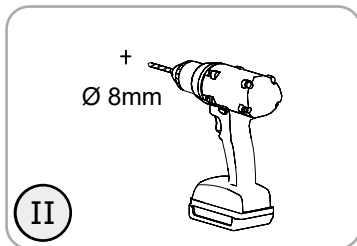
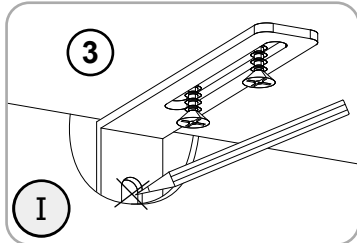
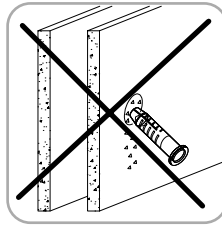
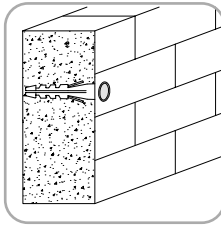

14

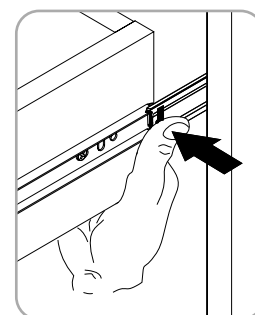
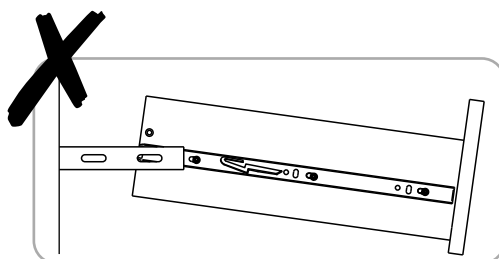
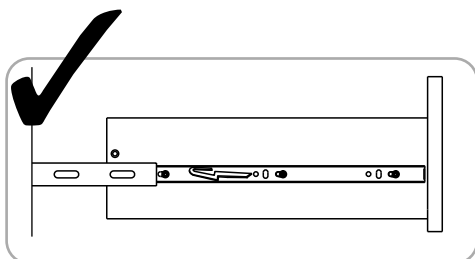
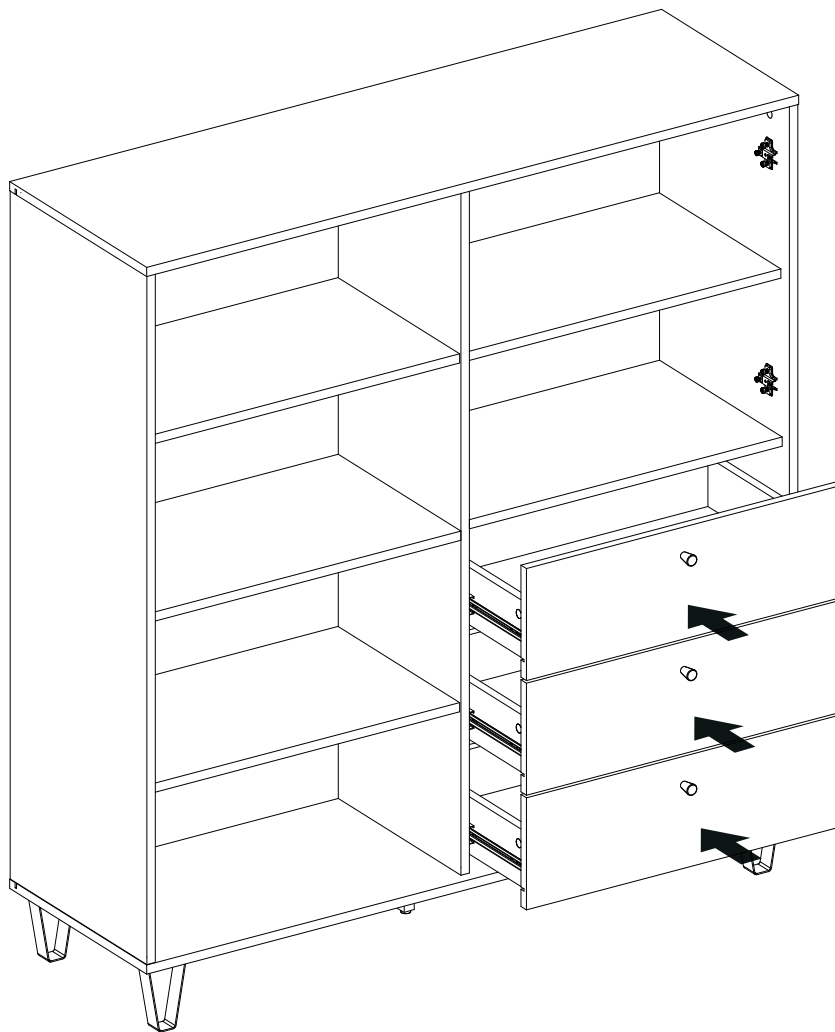
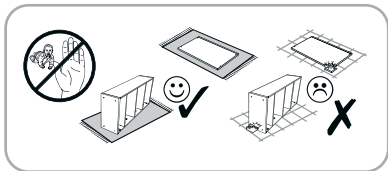

15

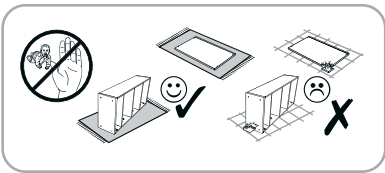

(K12)
 Ø35 x4

(D11)
 3,5x16 x8

(J60)
 Ø19 x2

(DB2)
 4x25 x2

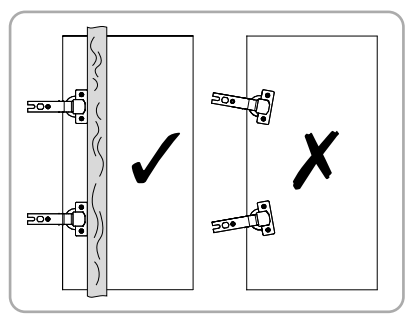
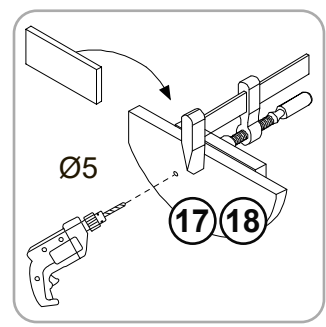
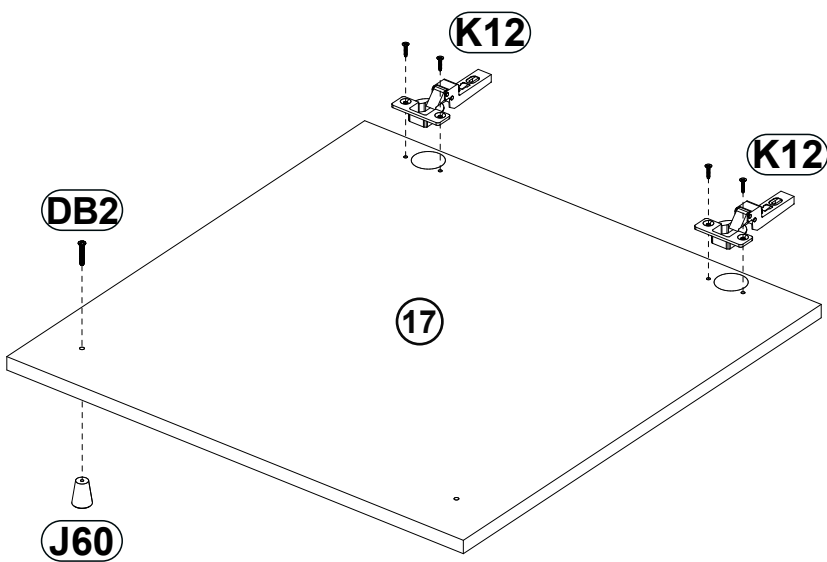
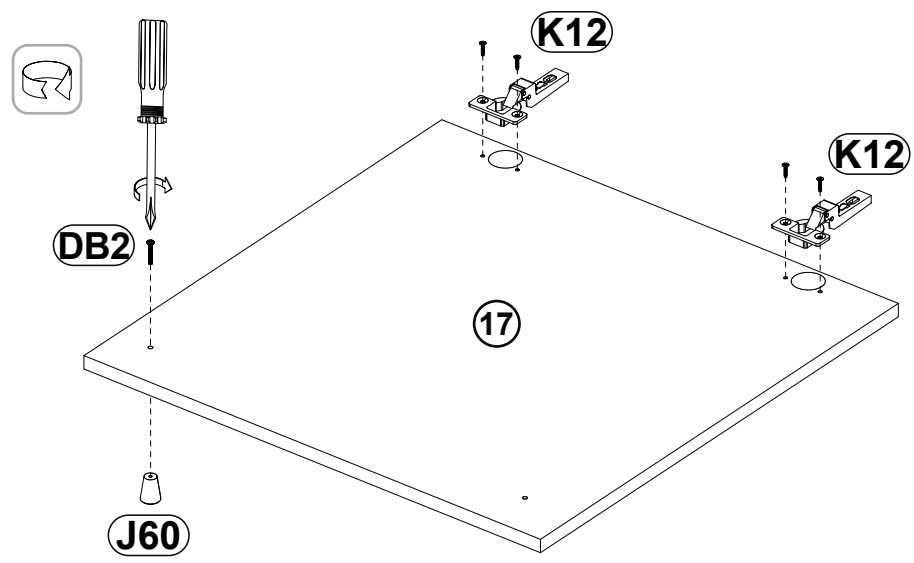
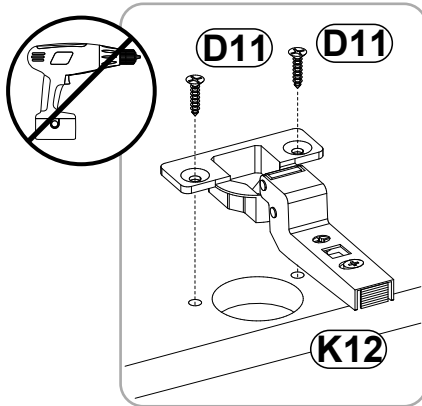

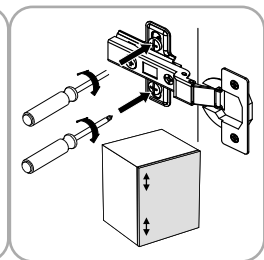
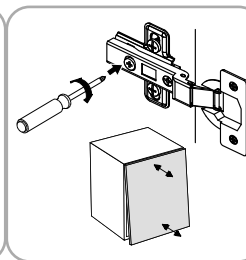
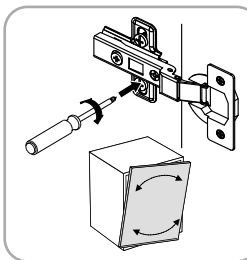
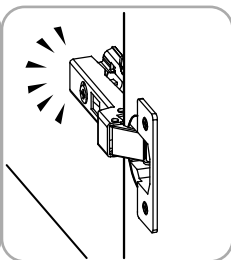
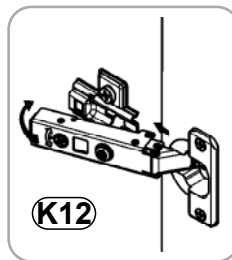
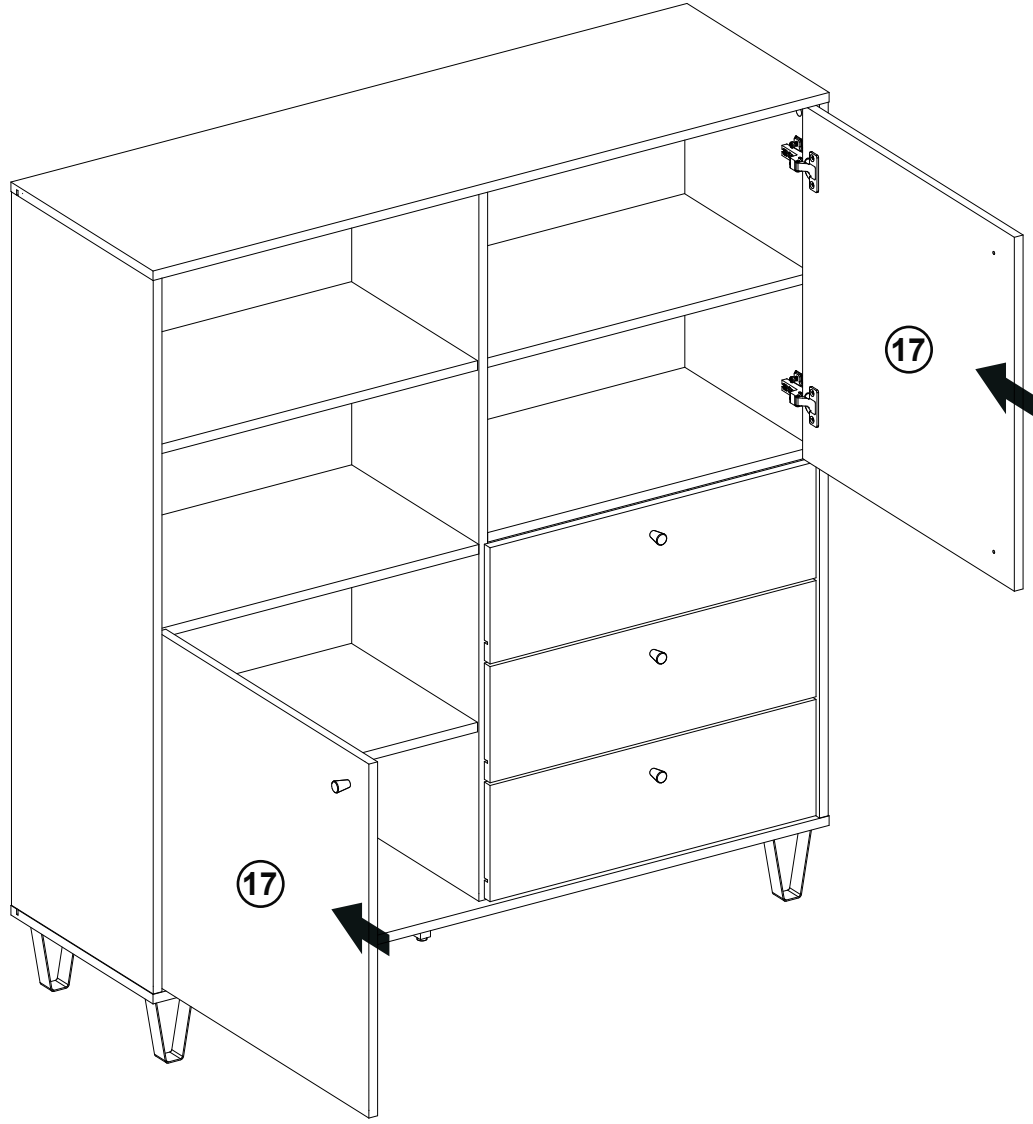

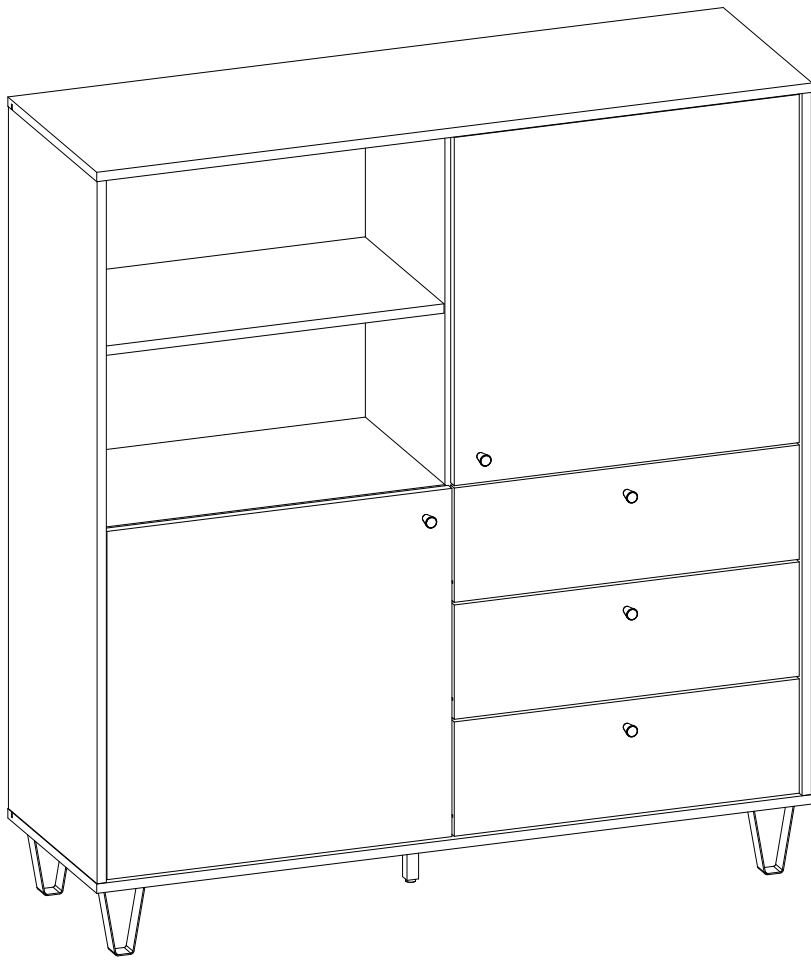

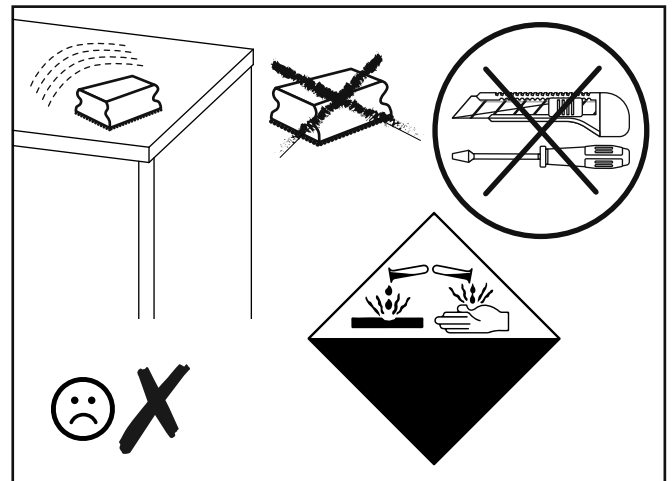
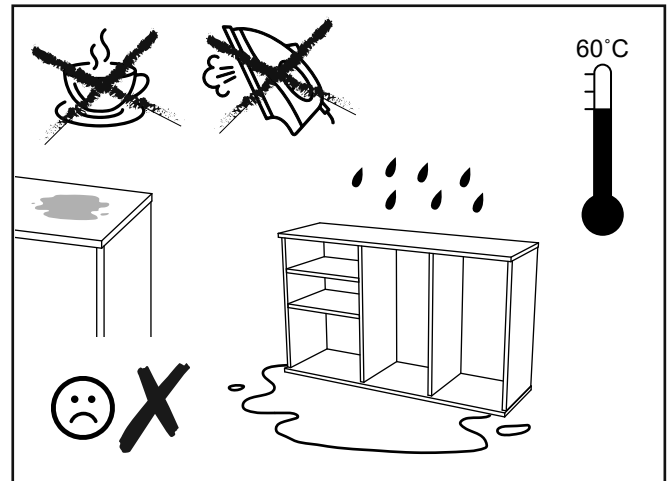
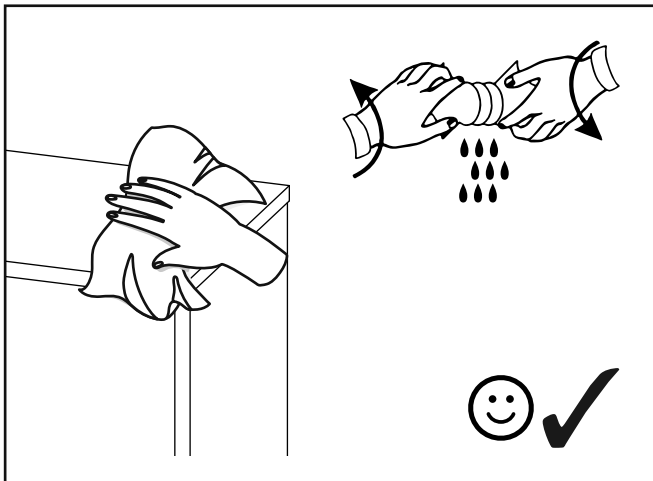
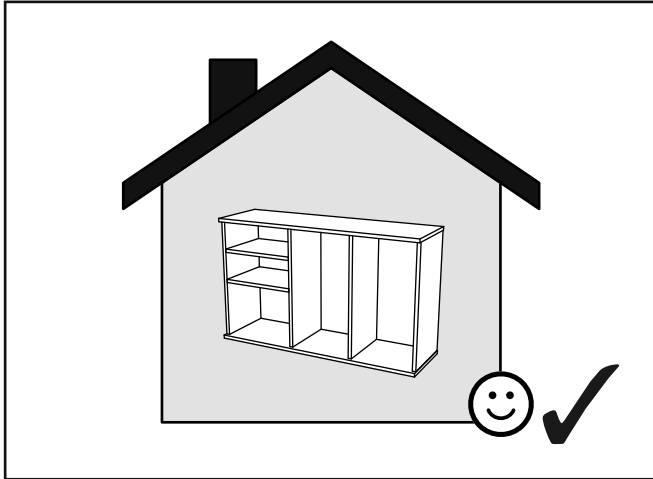

- PL** Powierzchnię mebli należy czyścić tylko środkami do pielęgnacji mebli. Szanowny kliencie w przypadku reklamacji prosimy wypełnić druki reklamacyjne dostępne w punktach sprzedaży przedkładając Kartę Reklamacyjną (zawierającą datę produkcji i numer pakowacza lub zmiany pakowania) umieszczoną w każdej z paczek, oraz instrukcję montażu mebla, gdzie prosimy o zaznaczenie uszkodzonego elementu.
- SK** Povrch nábytku čistite iba prostriedkami určenými na ošetrovanie nábytku.Vá ení zákazníci! V prípade reklamácie prosíme, aby ste vyplnili tlačivá, ktoré sú prístupné v obchodoch, predlo ili Reklamačný list (ktorý obsahuje dátum výroby a číslo baliča alebo číslo zmeny pri balení), ktorý sa nachádza v ka dom balení a návod na montá nábytku, v ktorom označte poškodenú čas.
- CZ** Povrch nábytku čistíte pouze přípravky určenými k ošetřování nábytku.Vá ený zákazník, v případě uplatnění reklamacce vyplňte prosím reklamační formuláře, které jsou dostupné v prodejnách a předlo te Reklamační kartu (obsahující datum výroby a číslo balení nebo změny balení, která je umístěna v balíčku) a návod k obsluze s vyznačením poškozeného dílu.
- BG** Повърхността на мебелите трябва да се почиства само с препарати за поддържане на мебелите.Уважаеми клиенти, в случай на рекламация моля попълнете формулярите за рекламация, които ще получите в търговските пунктове, като представите Картата за рекламация (съдържаща датата на производство и номера на опаковчика или смяната за опаковане), която ще намерите във всяка опаковка, и инструкцията за монтаж на мебела, върху която да отбележите повредения елемент.
- RO** Suprafața ei trebuie să fie curățată numai cu substanțe destinate pentru curățarea mobilei.Stimate Cumpărător, în caz de reclamație vă rugăm să completați formularul de reclamație pe care îl puteți lua de la punctul de vânzare și pe care îl veți prezenta împreună cu Cartela de Garanție (care conține data producției și nr ambalatorului sau turei de ambalare), însoțită la fiecare ambalaj, precum și instrucțiunile de montaj ale mobilei, pe care vă rugăm să marcați elementul deteriorat.
- UA** Поверхню меблів потрібно чистити тільки засобами для догляду за меблями.Шановний клієнте для заяви рекламачії, просимо заповнити формуляр рекламачії, доступний у пунктах продажу, вказуючи рекламачійну карту (містить дату виробництва та номер пакувальника або зміни упаковки), прикладену до кожного пакету, а також інструкцію з монтажу меблів, на якій просимо позначити пошкоджений елемент.
- RUS** Поверхность мебели надо чистить только средствами для ухода за мебелью.Уважаемый клиент для заявления рекламации, просим заполнить формуляр рекламации, доступный в пунктах продажи, указывая Рекламационную карту (содержащую дату производства и номер упаковщика или смены упаковки), приложенную к каждому пакету, а также инструкцию по монтажу мебели, на которой просим обозначить поврежденный элемент.
- DE** Reinigen Sie den Möbelbereich nur mit Möbelpflege. Kunden, bei Beanstandung Bitte füllen Sie die Reklamationsformulare, die in den Verkaufsabteilungen erhältlich sind, vor dem Verkauf aus eine Reklamationskarte (mit Angabe des Produktionsdatums und der Anzahl der Personen, die die Waren verpacken, oder der Anzahl der Schichten)Verpackung), die in jeder Packung enthalten ist, und Halterungen, in denen Sie reichlich vorhanden oder beschädigt sind ElementeReinigen Sie den Möbelbereich nur mit Möbelpflege. Kunden, bei Beanstandung.
- GB** Furniture surface must be cleaned only with furniture maintenance formulas.Dear Customer, should you wish to file a complaint, we would request you to fill in the complaint forms available in our outlets, submitting the Complaint Card (specifying the date manufactured, packaging employee/ shift code) enclosed in each of the packets, together with the Assembly Manual, where please highlight the faulty component.
- H** A bútorok felületét kizárólag a bútorápolószerekkel lehet tisztítani. Tisztelt Vásárló! Reklamáció esetén kérjük az eladási helyeken kapható reklamációs nyomtatványokat kitölteni a Reklamációs Lap (tartalmazza a gyártási dátumát és csomagoló számát vagy műszakszámát) bemutatásával, amely mindegyik csomagban található, valamint a bútor szerelési utasítását, amelyen kérjük a sérült elemet bejelölni sziveskedjék.
- FR** La surface des meubles ne peut être nettoyée qu'avec des produits pour l'entretien de meubles. Cher Client, en cas de réclamation, veuillez bien remplir des formulaires de réclamation accessibles dans les centres de vente en montrant le mode d'emploi pour monter le meuble. Nous vous demandons de bien vouloir y entourer l'élément en panne.
- ES** Limpiar la superficie de muebles exclusivamente con los agentes para el cuidado de los muebles.Estimado Cliente, en caso de reclamaciones, hagan favor de rellenar los formularios de reclamación disponibles en los puntos de venta, presentando las instrucciones de montaje de mueble, donde es necesario indicar un elemento estropeado.
- NL** Het oppervlak van meubels hoeft alleen te worden gereinigd door middel van meubelverzorging Beste klant voor de verklaring!
klacht, vul dan het klachtenformulier in dat beschikbaar is in de verkooppunten, met vermelding van: klachtenkaart (bevat de fabricagedatum en het nummer van de verpakker of verandering van verpakking), bevestigd aan elk pakket, evenals instructies voor het installeren van meubels, die we u vragen te markeren beschadigd item.
- IT** Pulire le superfici dei mobili solo con gli appositi detergenti. Gentile Cliente, se desidera presentare un reclamo, Le chiediamo di compilare i moduli di reclamo disponibili presso i nostri punti vendita, presentando la Scheda di reclamo (specificando la data di produzione, l'imballaggio della merce o il numero di strati di imballaggio) allegata a ciascuna confezione, insieme al manuale di montaggio, dove si prega di evidenziare l'articolo difettoso.