

6006 ARTIK

V.01 - 11/22

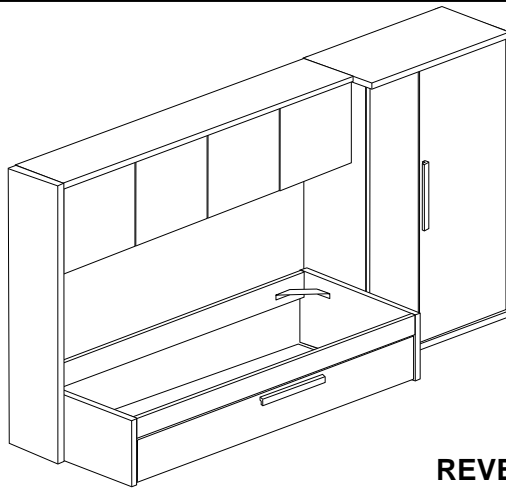

REVERSIBLE



120 min



x2

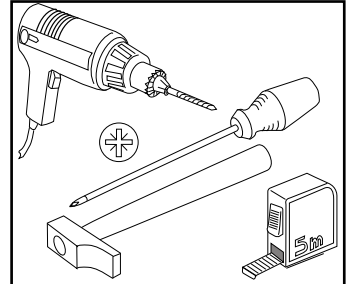

600612

600621

600615

600601

600616

600620

600631

600602

600613

600604

600605

600606

600603

600604

600601

600630

600619

600614

600617

600617

600618

600618

600622

600607

600608

600611

600611

600607

600610

ANTES DE EMPEZAR CONSULTE LOS CONSEJOS PARA EL MONTAJE.

AVANT DE COMMENCER CONSULTEZ LES INSTRUCTIONS DE MONTAGE.

BEFORE STARTING REFER TO THE ASSEMBLY ADVICE.

VOR DEM BEGINN EMPFIEHLT ES SICH AUFMERKSAM DIE HINWEISE ZUR MONTAGE ZU LESEN.

ANTES DE COMEÇAR CONSULTE OS CONSELHOS PARA A MONTAGEM.

RAADPLEEG VOORDAT U BEGINT HET MONTAGE-ADVIES.

PRED ZACÁNÍM SE PROSÍM MONTÁŽNÍ PORADENSTVÍ

اقرأ تعليمات التجميع بعناية

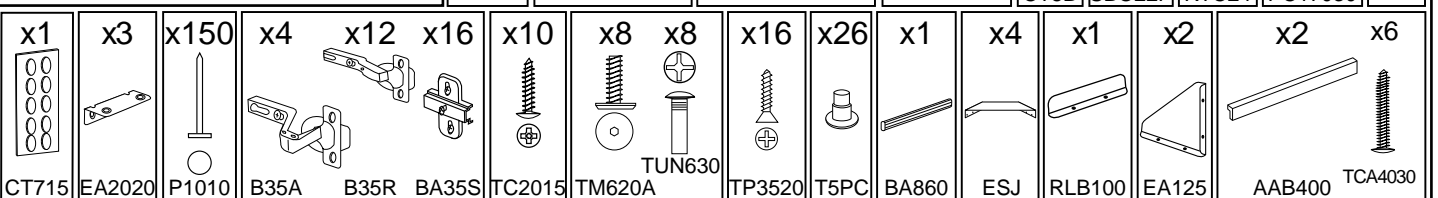
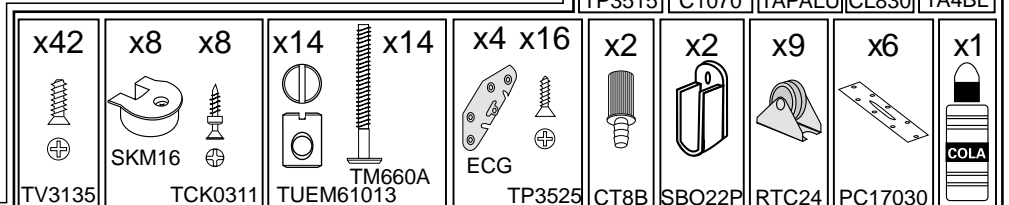
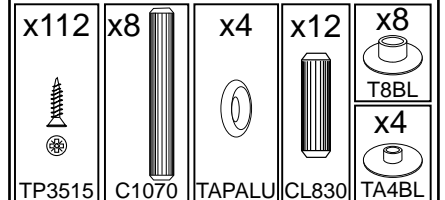
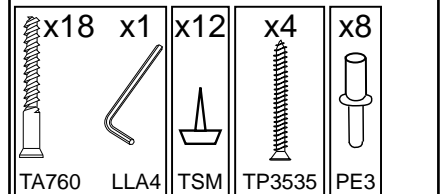

Español (es) - Información importante sobre el montaje de los muebles en pared, leer detenidamente y guardar esta información para consultarla en el futuro.

ADVERTENCIA

Una vez montado según las instrucciones de montaje, el mueble está listo para fijarlo a la pared. Pueden producirse lesiones graves o fatales si vuelca un mueble. Para evitar que vuelque este mueble, debe fijarse permanentemente a la pared. Trasman Penedès no se hace responsable de daños personales ocasionados por un montaje de pared incorrecto.

No están incluidos los tornillos para montaje en pared. Póngase en contacto con su ferretero local que le asesorará en la elección del sistema de tornillos correcto para el tipo de material de pared, dado que los diversos materiales de pared requieren diferentes tipos de herrajes de fijación.

Français (fr) - Informations importantes concernant le montage mural de notre mobilier, a lire attentivement, conserver ces informations pour un usage ultérieur.

AVERTISSEMENT

Après avoir assemblé votre meuble en suivant le mode d'emploi, vous pouvez le monter au mur. Risque de blessure grave en cas de chute du meuble. Pour éviter que le meuble ne bascule, il faut le fixer au mur de façon permanente. Trasman Penedès décline toute responsabilité en cas de blessures ou de dommages matériels dus à un montage mural incorrect.

Aucune vis n'est fournie pour le montage mural. Contactez votre quincaillier local pour sélectionner une visserie adaptée au matériau de construction de votre mur, car leur choix dépend du matériau du mur sur lequel est fixé le meuble.

English (en) - Important information concerning wall mounting of furniture, read carefully and keep this information for further reference.

WARNING

After you have assembled this product according to the assembly instructions, it can be mounted on a wall. Serious or fatal crushing injuries can occur from furniture tip-over. To prevent this furniture from tipping over it must be permanently fixed to the wall. Trasman Penedès cannot be held liable for personal or material injury as a result of incorrect mounting.

Screws for wall mounting are not included. Please contact your local specialist to ensure the correct choice of screws in relation to the wall material since different wall materials require different types of fixing devices. Use fixing devices suitable for the walls in your home.

Italiano (it) - Informazioni importanti per il fissaggio alla parete dell'armadietto per le scarpe, leggi attentamente e conserva queste informazioni per ulteriori consultazioni.

AVVERTENZA

Durante il montaggio questo armadietto per le scarpe andrà fissato alla parete. Se il mobile si ribalta può causare lesioni da compressione serie o fatali. Per prevenire il rischio che il mobile si ribalti permanentemente alla parete. Trasman Penedès non potrà essere ritenuto responsabile dei danni a persone o cose dovuti ad un montaggio non corretto.

Le viti per il fissaggio a parete non sono in dotazione. Rivolgersi al locale negoziante specializzato per essere sicuri che le viti corrispondano al materiale della parete perché pareti di materiali diversi richiedono tipi diversi di accessori di fissaggio.

Deutsch (de) - Wichtige Information betr. Wandbefestigung des Schuhschranks, sorgfältig lesen, diese Information aufbewahren

ACHTUNG

Beim Zusammenbau dieses Schanks müssen Sie das Möbelstück an der Wand befestigen. Wenn Möbelstücke umkippen, können ernste oder lebensgefährliche Verletzungen durch Einklemmen die Folge sein. Um zu verhindern, dass das Möbelstück umkippt, muss es fest an der Wand verankert werden. Trasman Penedès haftet nicht für Personen- oder Sachschäden, die auf eine unsachgemäße Wandmontage zurückgeführt werden können.

Schrauben für die Wandmontage gehören nicht zum Lieferumfang. Für die korrekte Wahl eines für das jeweilige Wandmaterial geeigneten Schraubensystems wenden Sie sich bitte an den Fachhandel vor Ort, da dieses von der jeweiligen Wandbeschaffenheit abhängig ist.

Português (pt) - Informação importante relativa a montagem na parede do móvel, ler estas instruções cuidadosamente, guardar como referência.

IMPORTANTE

Depois de ter montado o móvel de acordo com as instruções de montagem, pode fixá-lo à parede. As quedas de móveis podem originar esmagamento ou morte. Estes móveis devem ser fixados à parede para evitar possíveis quedas. Trasman Penedès não se responsabiliza por ferimentos pessoais ou danos materiais ou danos como resultado da montagem incorrecta.

Os parafusos necessários para fixar o móvel à parede não estão incluídos. Por favor, contacte o seu especialista local para garantir a escolha correcta de parafusos em relação ao material, os diferentes tipos de parede requerem diferentes tipos de ferragens.

ESPAÑOL

CONSEJOS PARA EL MONTAJE:

- 1-ESTUDIE ATENTAMENTE EL MANUAL DE MONTAJE.
- 2-LOCALICE LAS PIEZAS QUE CONSTITUYEN SU MUEBLE.
- 3-REUNA Y CONTROLE LOS HERRAJES SUMINISTRADOS.
- 4-EQUIPESE CON LAS HERRAMIENTAS NECESARIAS.
- 5-PREPARE UNA ZONA DE MONTAJE.

CONSEJOS PARA EL MANTENIMIENTO:

- 1-QUITAR EL POLVO CUIDADOSAMENTE.
- 2-HUMEDECER UN PAÑO SUAVE Y LIMPIO CON AGUA LIGERAMENTE ENJABONADA.

NO FUERCE NUNCA EN LAS UNIONES APRIETE LOS TORNILLOS DESPUES DE CIERTO TIEMPO DE UTILIZACION. CONSERVE SU MANUAL DE MONTAJE. SI FALTARA UNA PIEZA SERIA LA MANERA MAS FACIL DE COMUNICARLO A LA TIENDA.

NO USE NUNCA PRODUCTOS ABRASIVOS TALES COMO: LANA DE ACERO , LIJAS,DISOLVENTES,ETC. NO MOJAR NI SOMETER A GRANDES HUMEDADES AL MUEBLE.

FRANCAIS

INSTRUCTIONS DE MONTAGE:

- 1-LISEZ ATTENTIVEMENT LA NOTICE DE MONTAGE.
- 2-REPEREZ LES PIECES QUI COMPOSENT VOTRE MEUBLE.
- 3-REGROUPEZ ET VERIFIEZ LES FERRURES FOURNIES.
- 4-DOTEZ-VOUS DES OUTILS NECESSAIRES.
- 5-PREPAREZ UN ESPACE DE MONTAGE.

CONSEILS D'ENTRETIEN:

- 1-ENLEVEZ SOIGNEUSEMENT LA POUSSIERE.
- 2-HUMIDIFIEZ UN CHIFFON DOUX ET PROPRE AVEC DE L'EAU LEGEREMENT SAVONNEUSE.

LES MEUBLES CONTENANT DES PANNEAUX À BASE DE BOIS (PANNEAUX DE PARTICULES, PANNEAUX DE FIBRES, CONTREPLAQUÉ...) PEUVENT ÉMETTRE DES SUBSTANCES POLLUANTES DANS L'AIR INTÉRIEUR. IL EST AINSI RECOMMANDÉ, APRÈS L'INSTALLATION DU MEUBLE DANS SON LOGEMENT, D'AÉRER FRÉQUEMMENT LA PIÈCE CONCERNÉE PENDANT AU MOINS QUATRE SEMAINES AFIN DE RÉDUIRE SON EXPOSITION AUX POLLUANTS ÉMIS PAR LE MEUBLE.

NE FORCEZ JAMAIS LES RACCORDS. RESSERREZ LES VIS APRES UN CERTAIN TEMPS D'UTILISATION. CONSERVEZ LA NOTICE DE MONTAGE. EN CAS DE PIECE MANQUANTE , CE SERA LE MEILLEUR MOYEN D'EN INFORMER LE MAGASIN.

N'UTILISEZ JAMAIS DES PRODUITS ABRASIFS COMME DE LA LAINE D'ACIER, DU PAPIER DE VERRE, DES SOLVANTS, ETC. NE MOUILLEZ PAS LE MEUBLE ET EVITEZ TOUTE ESPOSITION A UNE HUMIDITE IMPORTANTE.

ENGLISH

ASSEMBLY ADVICE:

- 1- STUDY THE ASSEMBLY MANUAL CAREFULLY.
- 2- LOCATE THE PARTS THAT COMPRISE YOUR FURNITURE ITEM.
- 3- ORGANISE AND CHECK THE FITTINGS SUPPLIED.
- 4- HAVE THE NECESSARY TOOLS TO HAND.
- 5- PREPARE AN ASSEMBLY AREA.

MAINTENANCE ADVICE:

- 1- REMOVE DUST CAREFULLY.
- 2- MOISTEN A SOFT, CLEAN CLOTH WITH SLIGHTLY SOAPY WATER.

DO NOT FORCE ANY OF THE JOINTS. TIGHTEN THE SCREWS AFTER HAVING USED THE FURNITURE FOR SOME TIME. KEEP YOUR ASSEMBLY MANUAL. IF ANY PART IS MISSING, IT WILL HELP YOU TO LET THE SHOP KNOW.

NEVER USE ABRASIVE PRODUCTS SUCH AS STEEL WOOL, SANDPAPER, ETC. DO NOT WET THE FURNITURE OR KEEP IT IN A VERY DAMP PLACE.

DEUTSCH

HINWEISE ZUR MONTAGE:

- 1- LESEN SIE AUFMERKSAM DIE MONTAGEANLEITUNG DURCH.
- 2- LOKALISIEREN SIE DIE ZUM MÖBEL GEHÖRENDE TEILE.
- 3- KONTROLLIEREN SIE DIE MITGELIEFERTEN WERKZEUGE.
- 4- RÜSTEN SIE SICH MIT DEN ZUSÄTZLICH BENÖTIGTEN WERKZEUGEN AUS.
- 5- BEREITEN SIE EINEN PLATZ FÜR DIE MONTAGE VOR.

HINWEISE ZUR PFLEGE:

- 1- ENTFERNEN SIE UMSICHTIG DEN ANGESAMMELTEN STAUB.
- 2- VERWENDEN SIE EIN WEICHES UND SAUBERES TUCH UND SCHWACHE SEIFENLAUGE.

FORCIEREN SIE NIEMALS DIE VERBINDUNGEN. ZIEHEN SIE DIE SCHRAUBEN NACH EINER BESTIMMTEN NUTZUNGSZEIT NACH. BEWAHREN SIE DIE MONTAGEANLEITUNG AUF. SOLLTE EIN TEIL FEHLEN IST SIE VON GROSSER WICHTIGKEIT BEI DER NACHBESTELLUNG IM LADEN.

VERWENDEN SIE NIEMALS SCHEUERENDE PRODUKTE WIE STAHLWOLLE, SCHMIRGELPAPIER, LÖSUNGSMITTEL UND DERGL. WASSER UND HOHE FEUCHTIGKEIT SIND SCHÄDLICH FÜR DAS MÖBEL.

POTUGUES

CONSELHO PARA A MONTAGEM :

- 1 - ESTUDE ATENTAMENTE O MANUAL DE MONTAGEM.
- 2 - LOCALIZE AS PEÇAS QUE CONSTITUEM O SEU MÓVEL.
- 3 - REUNA E CONTROLE AS FERRAGENS FORNECIDAS.
- 4 - EQUIPE-SE COM AS FERRAMENTAS NECESSÁRIAS.
- 5 - PREPARE UMA ZONA DE MONTAGEM.

CONSELHOS PARA A MANUTENÇÃO :

- 1 - RETIRAR A POEIRA COM CUIDADO.
- 2 - HUMEDECER UM PANO SUAVE E LIMPO COM ÁGUA LIGEIRAMENTE ENSABOADA.

NUNCA FORCE AS UNIÕES. APORTE OS PARAFUSOS DEPOIS DE DETERMINADO TEMPO DE UTILIZAÇÃO.. CONSERVE O SEU MANUAL DE MONTAGEM, SE FALTAR UMA PEÇA SERIA A MANEIRA MAIS FÁCIL DE A COMUNICAR À LOJA.

NUNCA USE PRODUTOS ABRASIVOS TAIS COMO : LÃ DE AÇO, LIXAS, DISSOLVENTS, ETC.. NÃO MOLAR NEM SUBMETTER A GRANDES HUMIDADES, O MÓVEL.

ITALIANO

CONSIGLI PER IL MONTAGGIO:

- 1- STUDIARE ATTENTAMENTE IL MANUALE DI MONTAGGIO.
- 2- INDIVIDUARE LE PARTI CHE COSTITUISCONO IL MOBILE.
- 3- RACCOLIERE E CONTROLLARE GLI ATTREZZI IN DOTAZIONE.
- 4- PROCURARSI GLI ATTREZZI NECESSARI.
- 5- PREPARARE UNA ZONA PER IL MONTAGGIO.

CONSIGLI PER LA MANUTENZIONE:

- 1- SPOLVERARE ACCURATAMENTE.
- 2- INUMIDIRE UN PANNINO MORBIDO E PULITO CON ACQUA E POCO DETERGENTE.

NON FORZARE MAI LE GIUNTURE. STRINGERE NUOVAMENTE LE VITI DOPO UN CERTO PERIODO D'USO. CONSERVARE IL MANUALE DI MONTAGGIO: SE MANCASSE UN PEZZO SAREBBE COSÌ PIÙ FACILE COMUNICARLO AL RIVENDITORE.

NON USARE MAI PRODOTTI ABRASIVI COME: SPUGNE ABRASIVE, CARTA VETRATA, SOLVENTI, ECC. NON BAGNARE NE' SOTTOPORRE IL MOBILE A FORTE UMIDITÀ.

اللغة العربية

تعليمات التجميع:

- 1-اقرأ تعليمات التجميع بعناية.
- 2-حدد موقع الأجزاء التي يتكون منها ذلك.
- 3-الجمع والتحقق من الأجهزة المقدمة.
- 4-هل لديك الأدوات اللازمة.
- 5- جهز مساحة التجميع.

إرشادات الصيانة:

- 1-قم بإزالة الغبار بعناية.
- 2-قم بتربيط قطعة كمالى ناعمة ونظيفة بالصابون الخفيف والماء.

لا تعرض التركيبات أبداً لشد الراس بعد وقت معين من الإستخدام. افظ تعليمات التجميع في حالة وجود جزء مفقود ، ستكون هذه أفضل طريقة لإعلام المتجر.

لا تستخدم أبداً المنتجات الكاشطة مثل الصوف الصلب ، ورق الرمل ، والمبيدات ، وما إلى ذلك. لا تلمس الأثاث وتجنب أي تعرض للرطوبة العالية.

HERRAJES

FERRURES

MÖBELBESCHLÄGE

ACCESSORI
PER MOBILI

FERRAGENS

OKUCIA
MEBLOWE

FURNITURE
FITTINGS

T1



x18

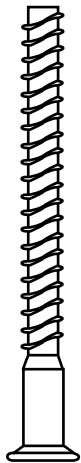

TA760

x1

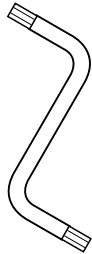

LLA4

x12

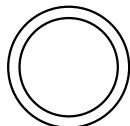
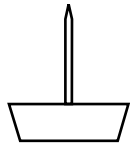

TSM

x4



TP3535

T2



x8



PE3

x112



TP3515

x8



CL1070

T3



x12

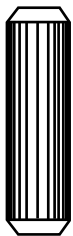

CL830

x4



TA4BL

x8



T8BL

x42



TV3135

T4



x8

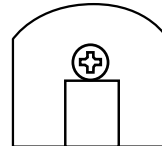
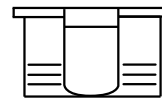

SKM16

x8



TCK0311

x14

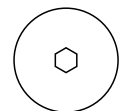
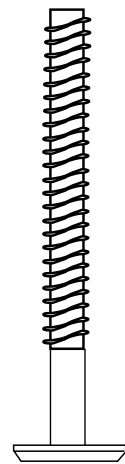

TCK0311

x14

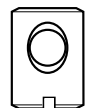

TUEM61013

T5



x16



TP3525

x4

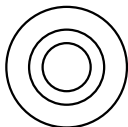
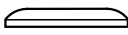

TAPALU

x2

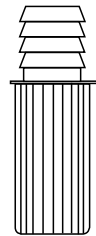

CT8B

x2



SBO22P

HERRAJES

FERRURES

MÖBELBESCHLÄGE

ACCESSORI
PER MOBILI

FERRAGENS

OKUCIA
MEBLOWE

FURNITURE
FITTINGS

W



x9

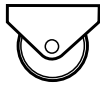

RTC24

x1

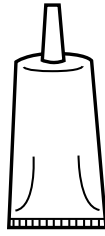

COLA

x1

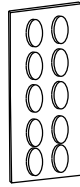

CT715

x3

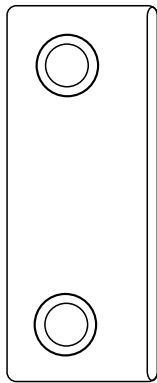

EA2020

x5



P1010

x4

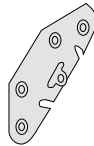

ECG

X



x6

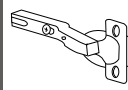

B35R

x6



BA35S

V



x6

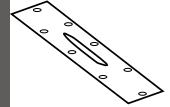

PC17030

T6



x10



TC2015

x8

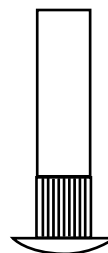

TUN630

x8

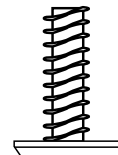

TM620A

x16



TP3520

Y



x6

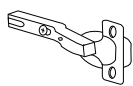

B35R

x6



BA35S

Z



x4

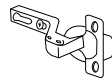

B35A

x4



BA35S

T7



x26



T5PC

AC



x1



BA860

x4

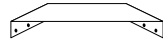

ESJ

x1



RLB100

x2

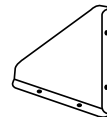

EA125

x2

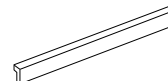

AAB400

1/7

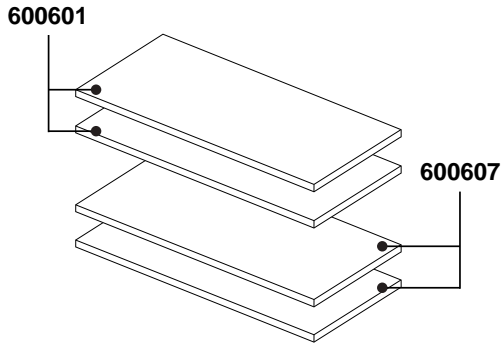

6006A

2/7

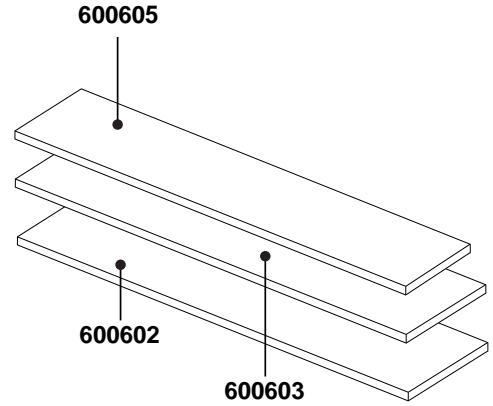

6006B

3/7

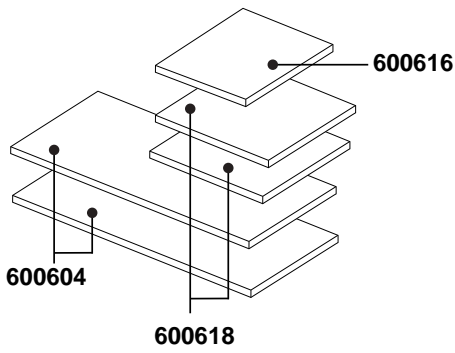

T1 T2
T3 T4
T5 T6
V W
X Y
Z AC

6006C

4/7

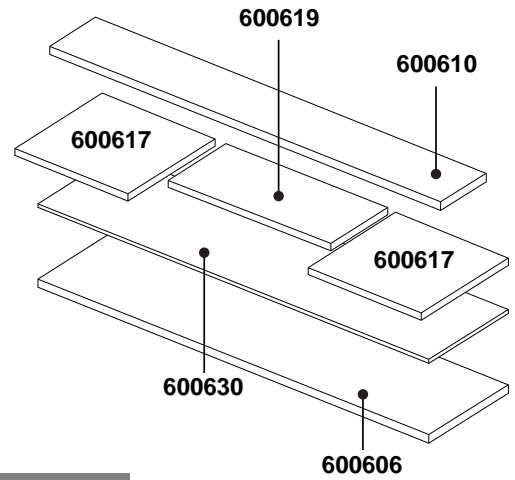

T7

6006D

5/7

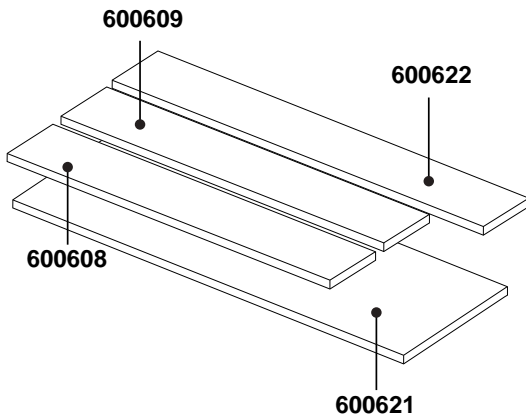

6006E

6/7

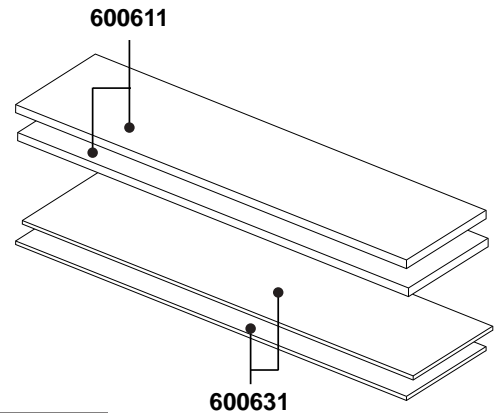

6006F

7/7

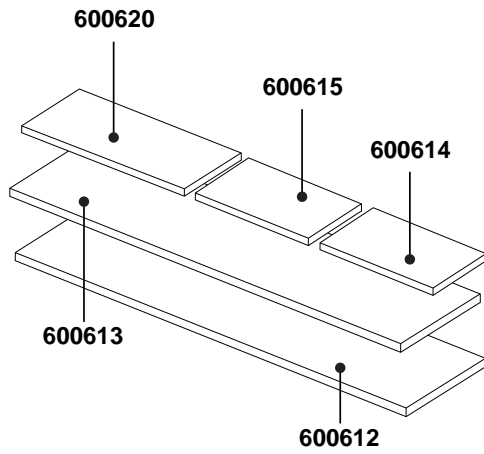

6006G

cm 0 1 2 3 4 5 6 7

C1070   x8

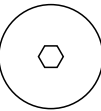
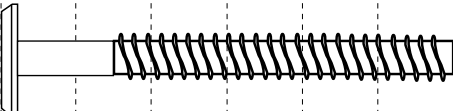
TM660A   x2

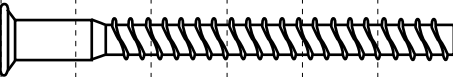
TA760   x2

cm 0 1 2

TUEM61013   x2

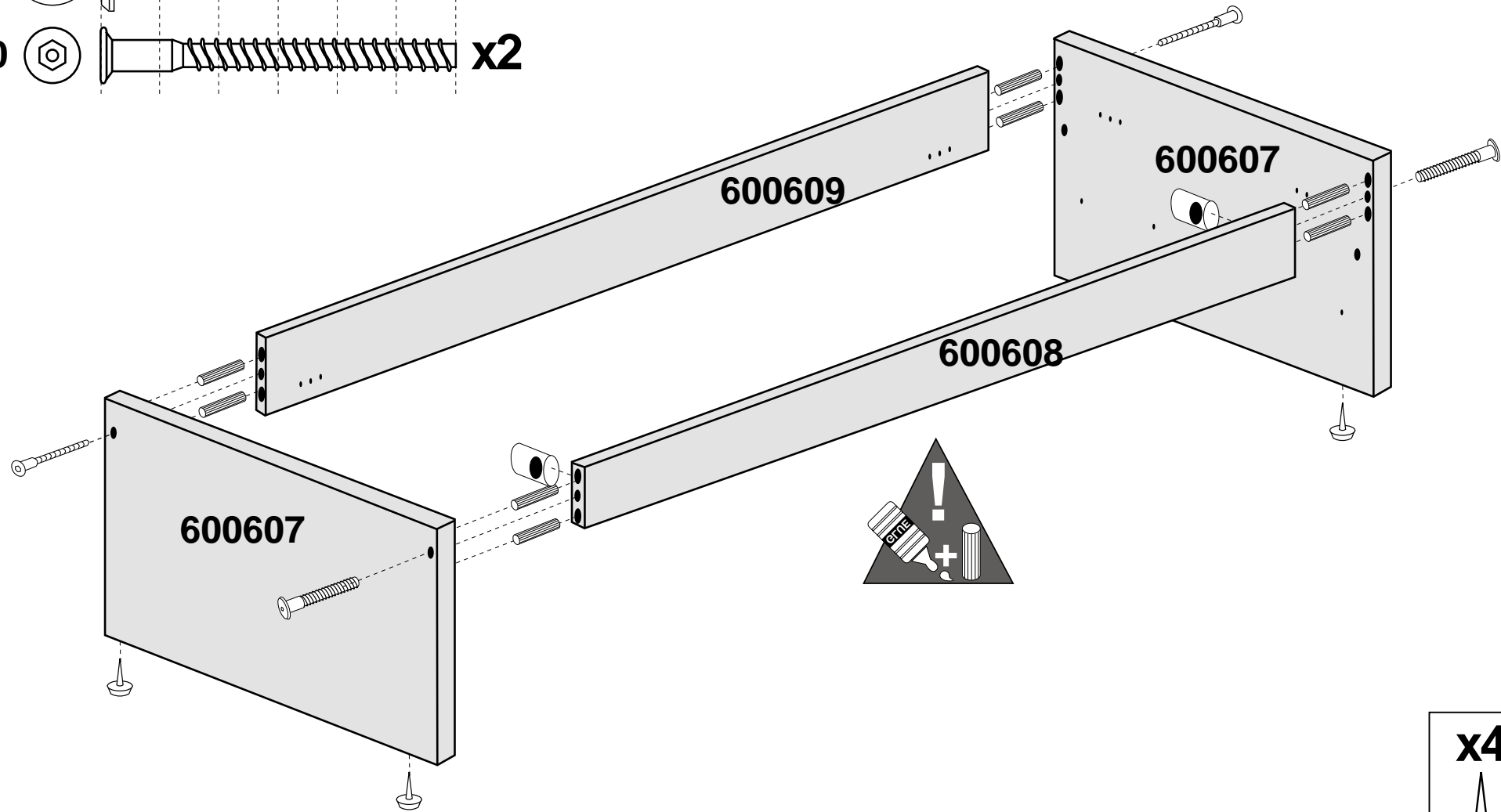

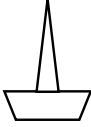
x4

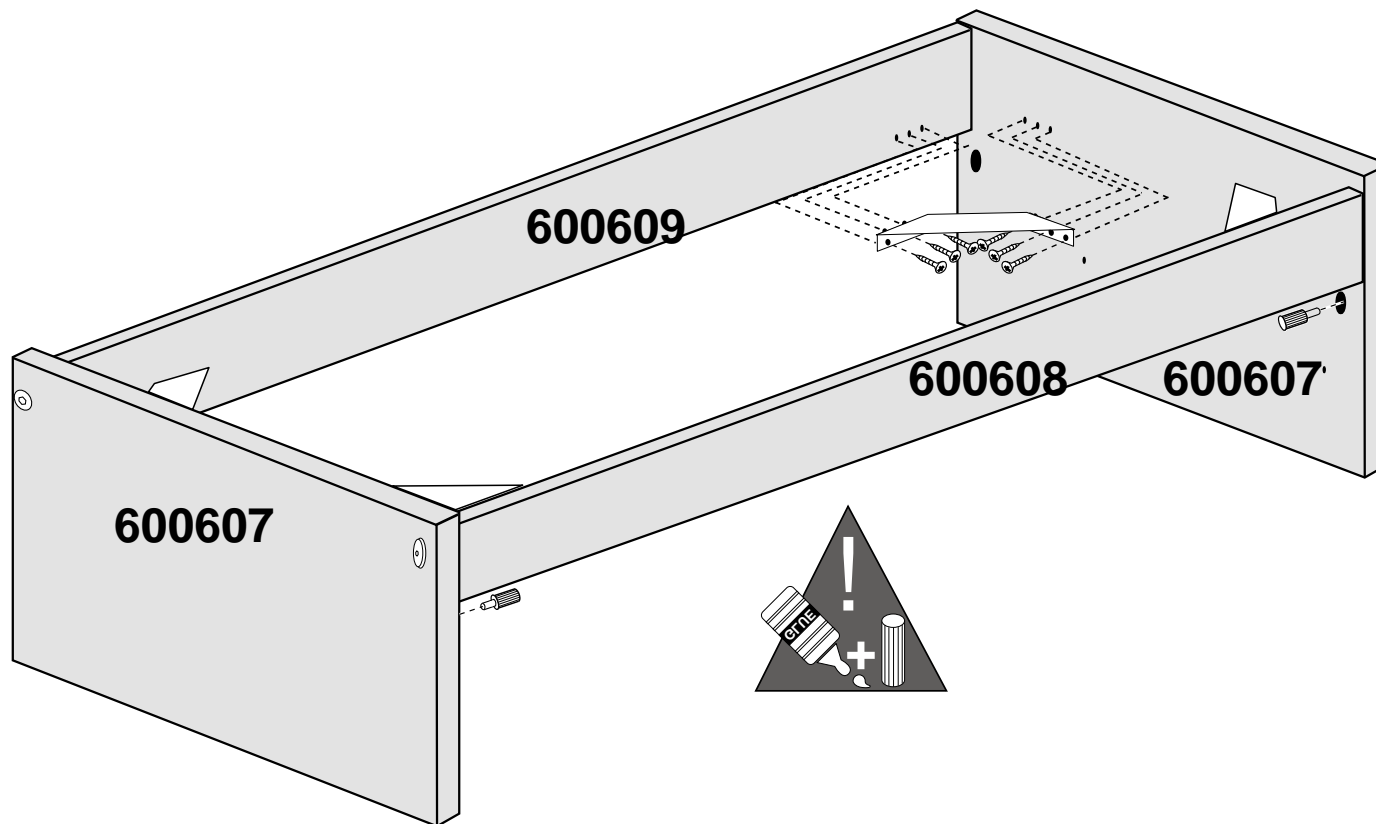
TSM

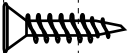

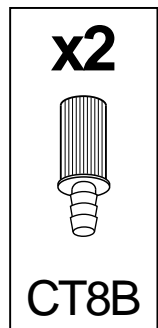
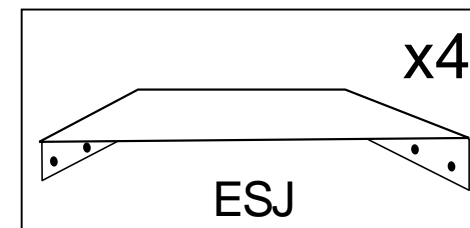
cm 0 1 2
TP3515   **x24**

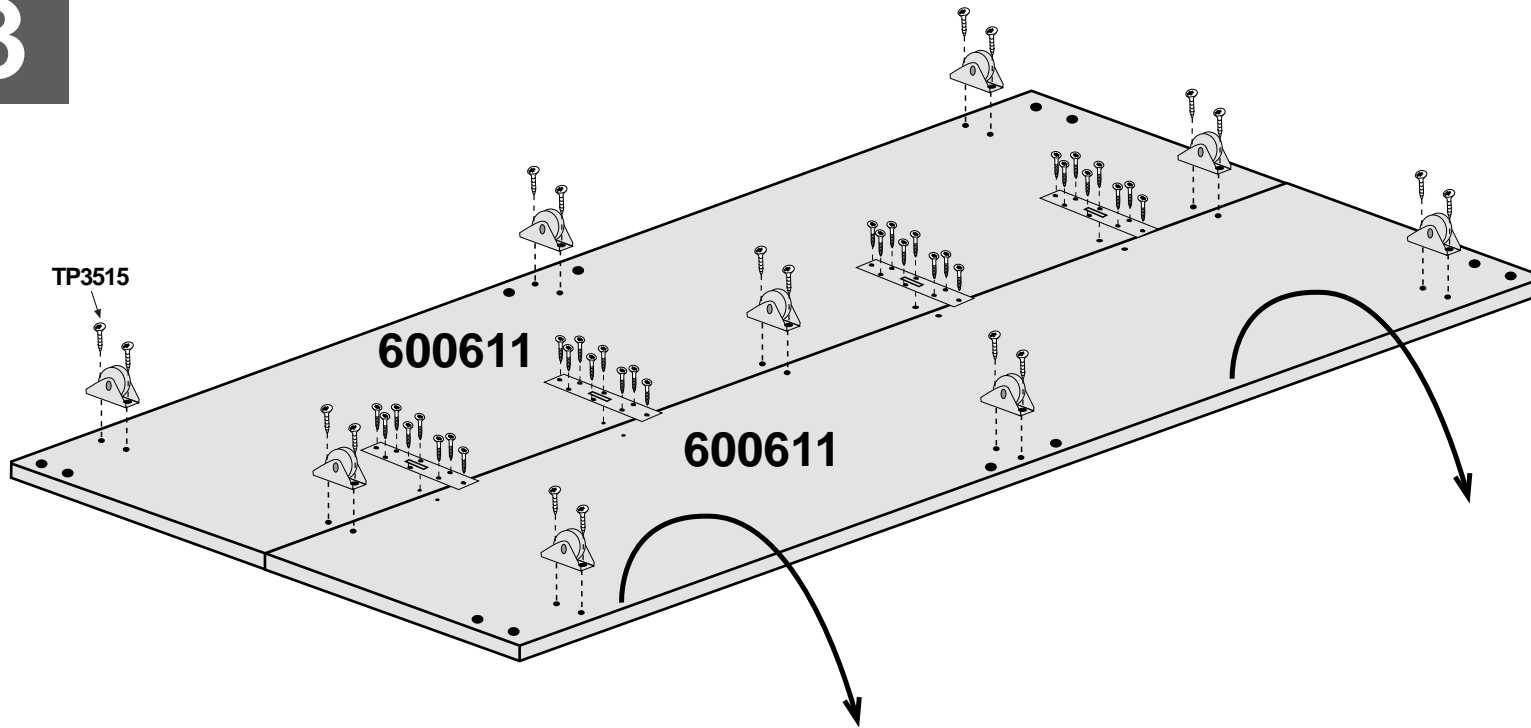

3



x9

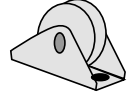

RTC24

x4

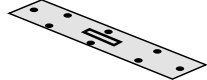

PC17030

TP3515   x50

4

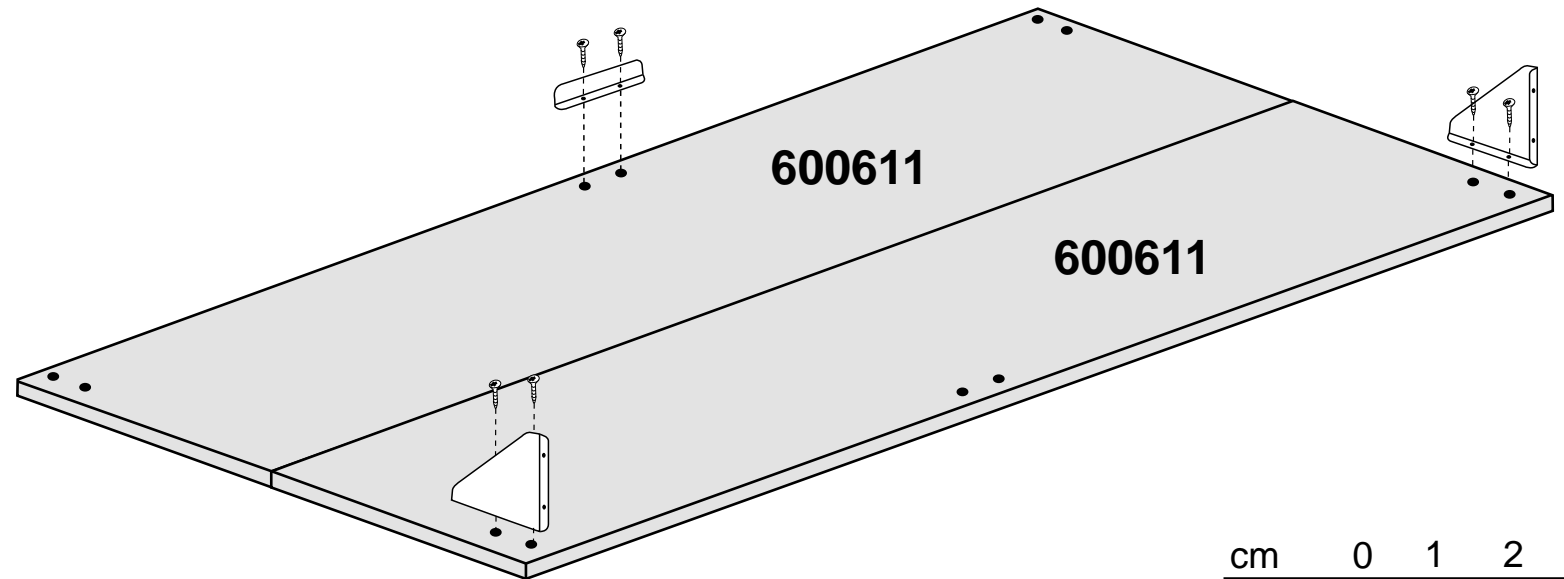

x2

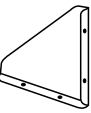

EA125

x1

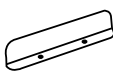

RLB100

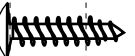
TC2015   x6

5

x14



T5PC

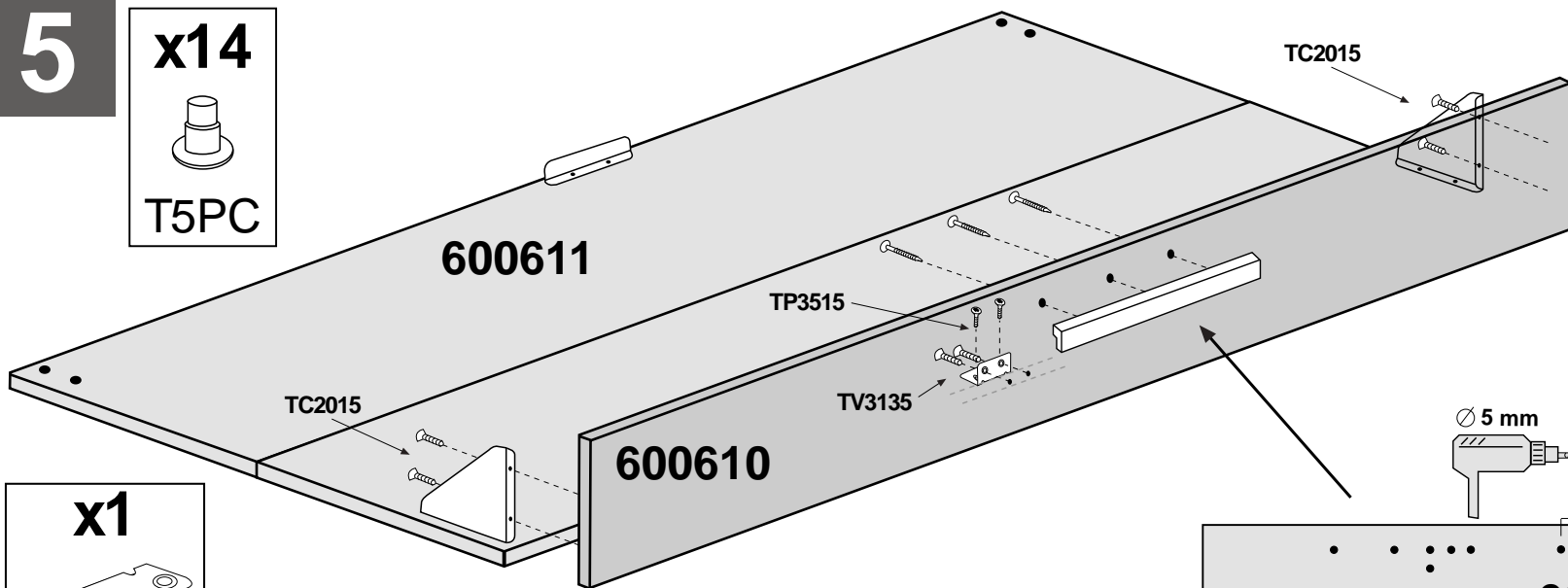

cm 0 1 2

TV3135 x2

TP3515 x2

TC2015 x4

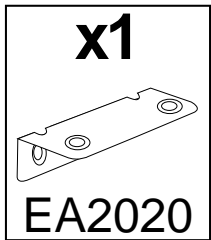

EA2020

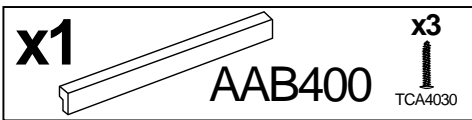

x1

AAB400

x3

TCA4030

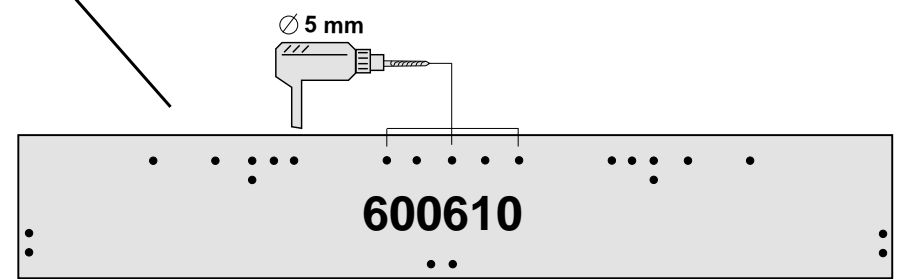

600610

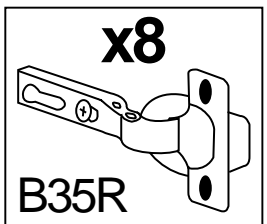

B35R

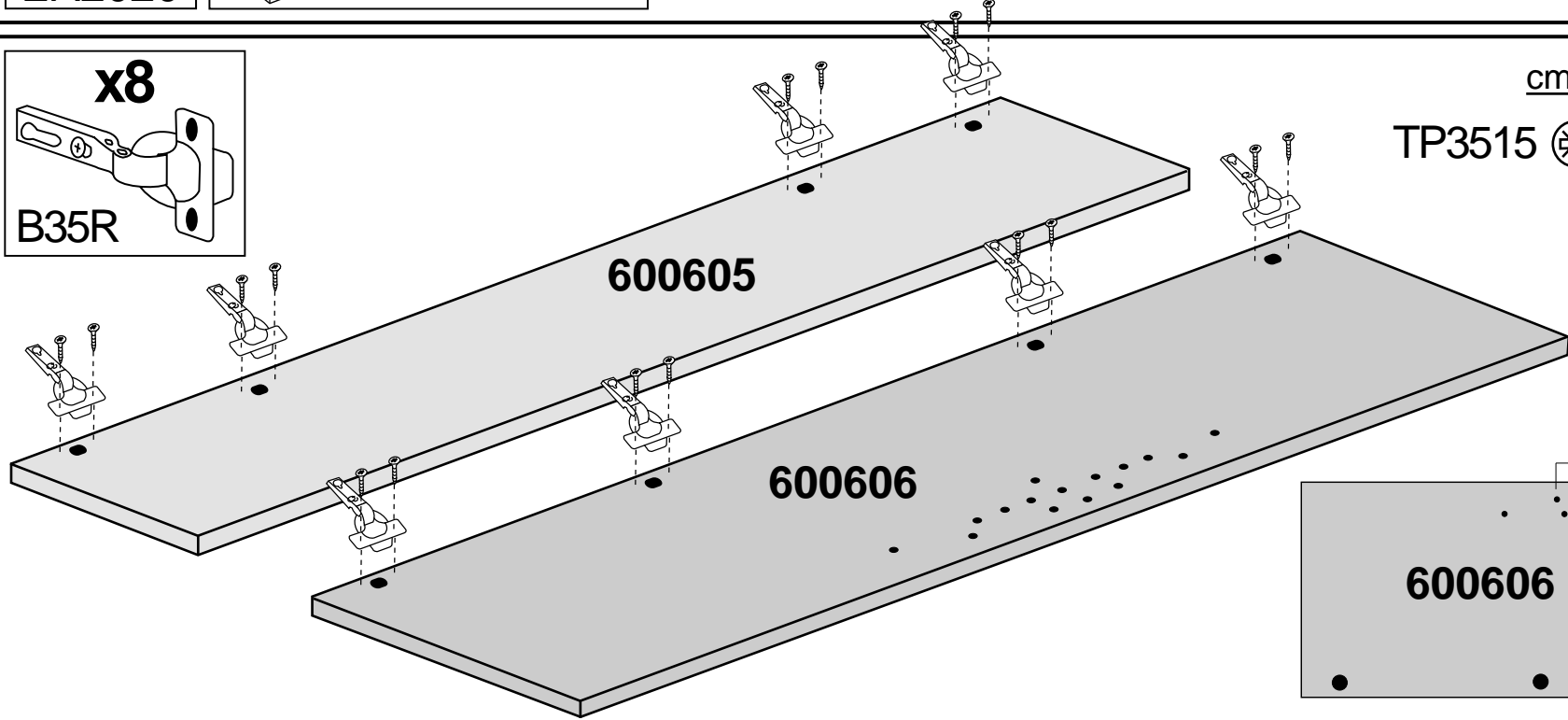

cm 0 1 2

TP3515 x16

6

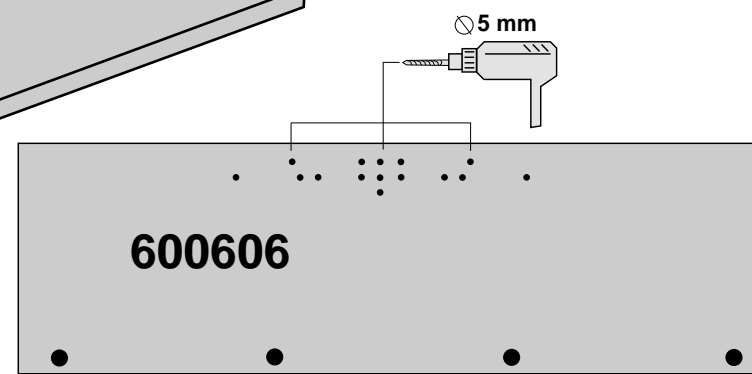

600606

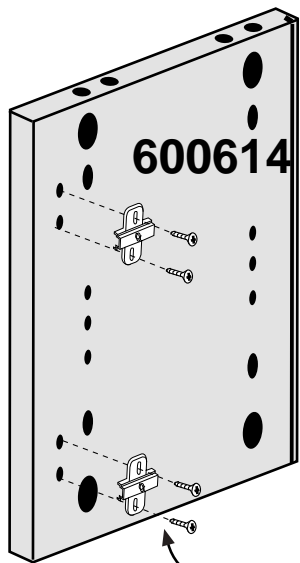

600614

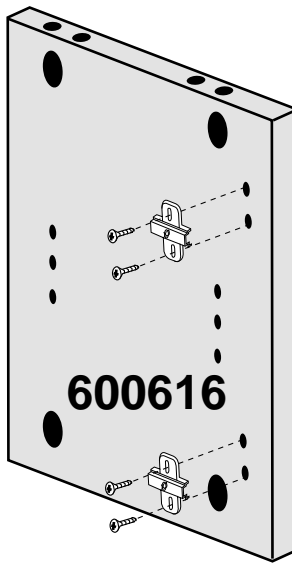

600616

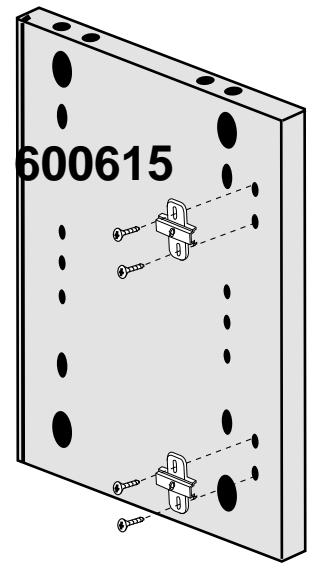

600615

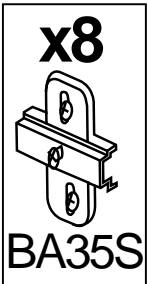

x8

BA35S

cm 0 1 2

TV3135   x16

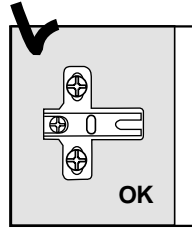

OK

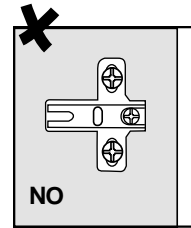

NO



7

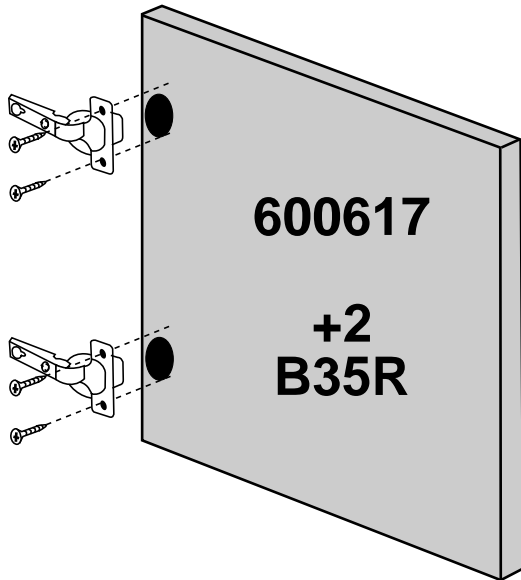

600617

+2

B35R

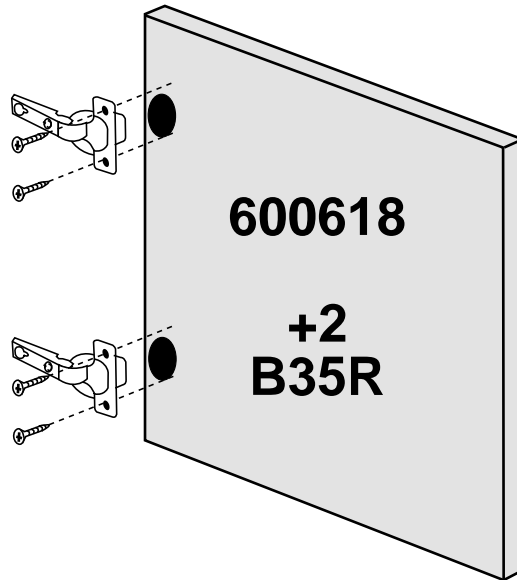

600618

+2

B35R

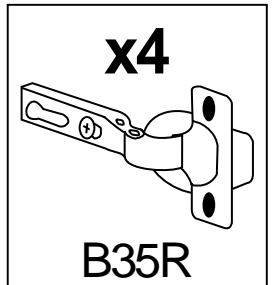

x4

B35R

cm 0 1 2

TP3515   x16

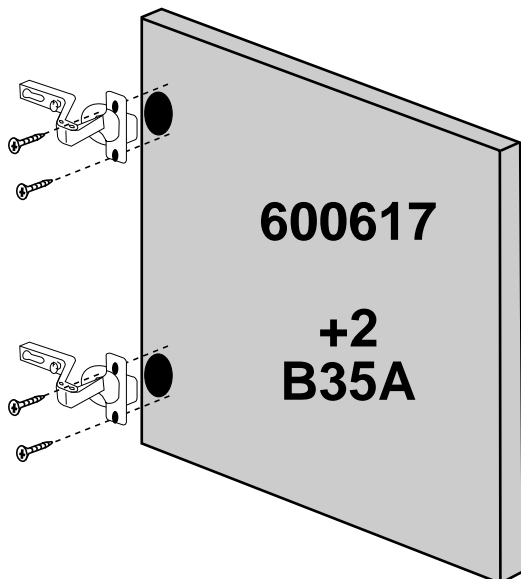

600617

+2

B35A

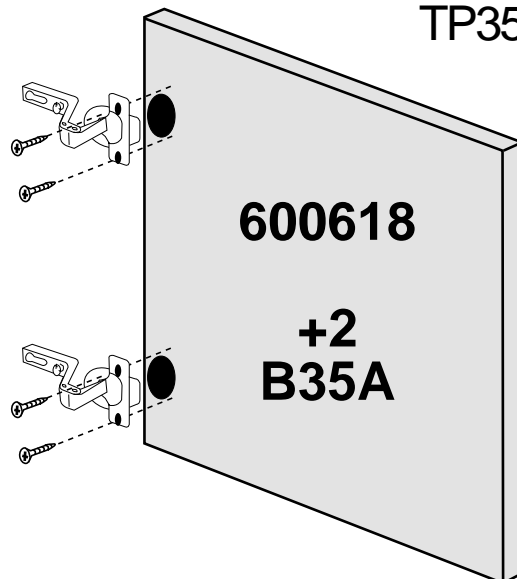

600618

+2

B35A

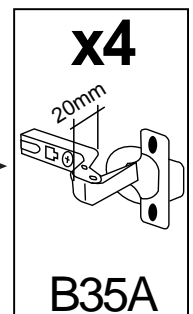

x4

B35A

8

cm 0 1 2 3 4 5 6

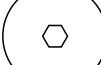
TM660A  **x6**

CL830  **x6**

TUEM61013  **x6**

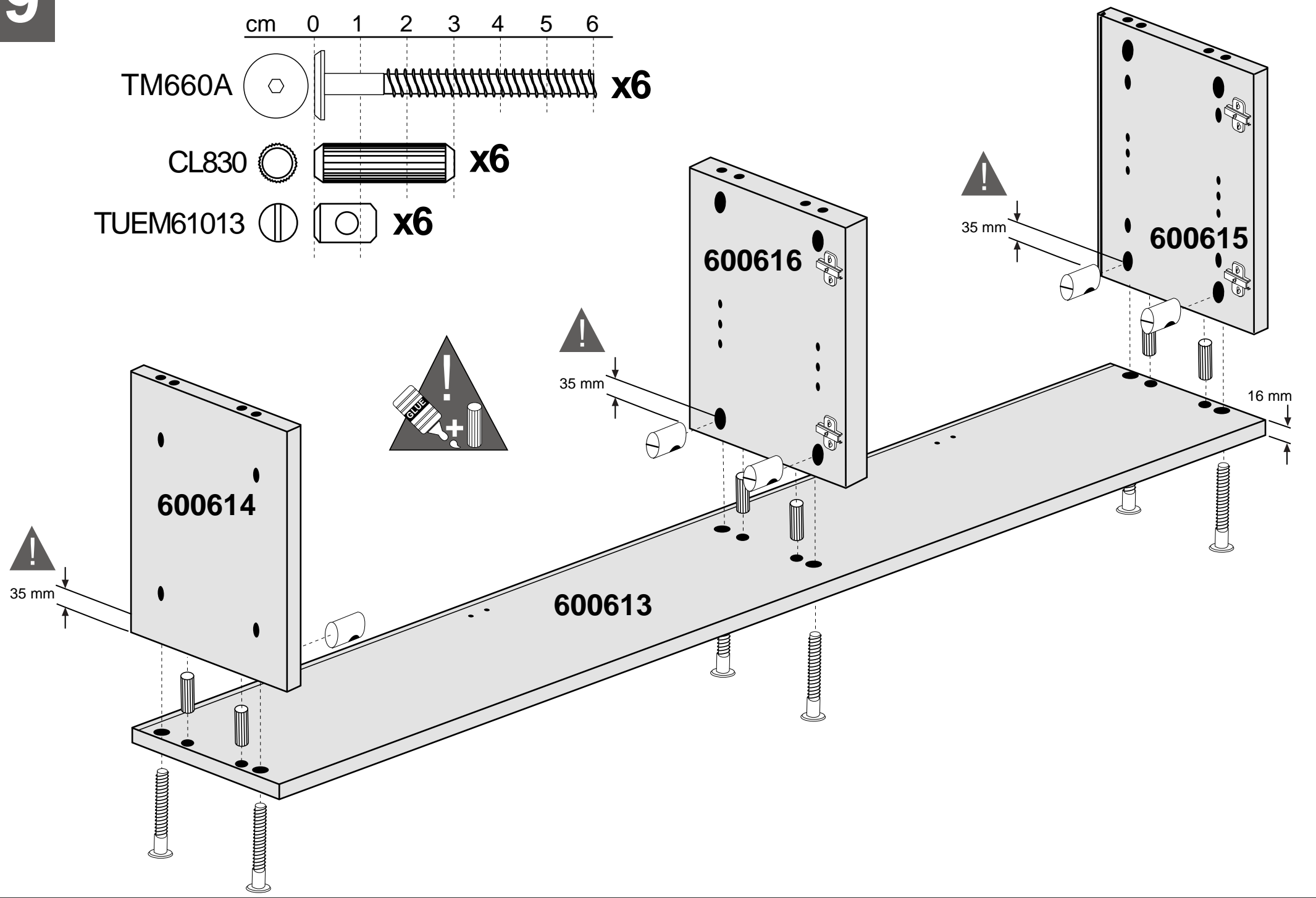

cm 0 1 2 3 4 5 6

TM660A  **x6**

CL830  **x6**

TUEM61013  **x6**

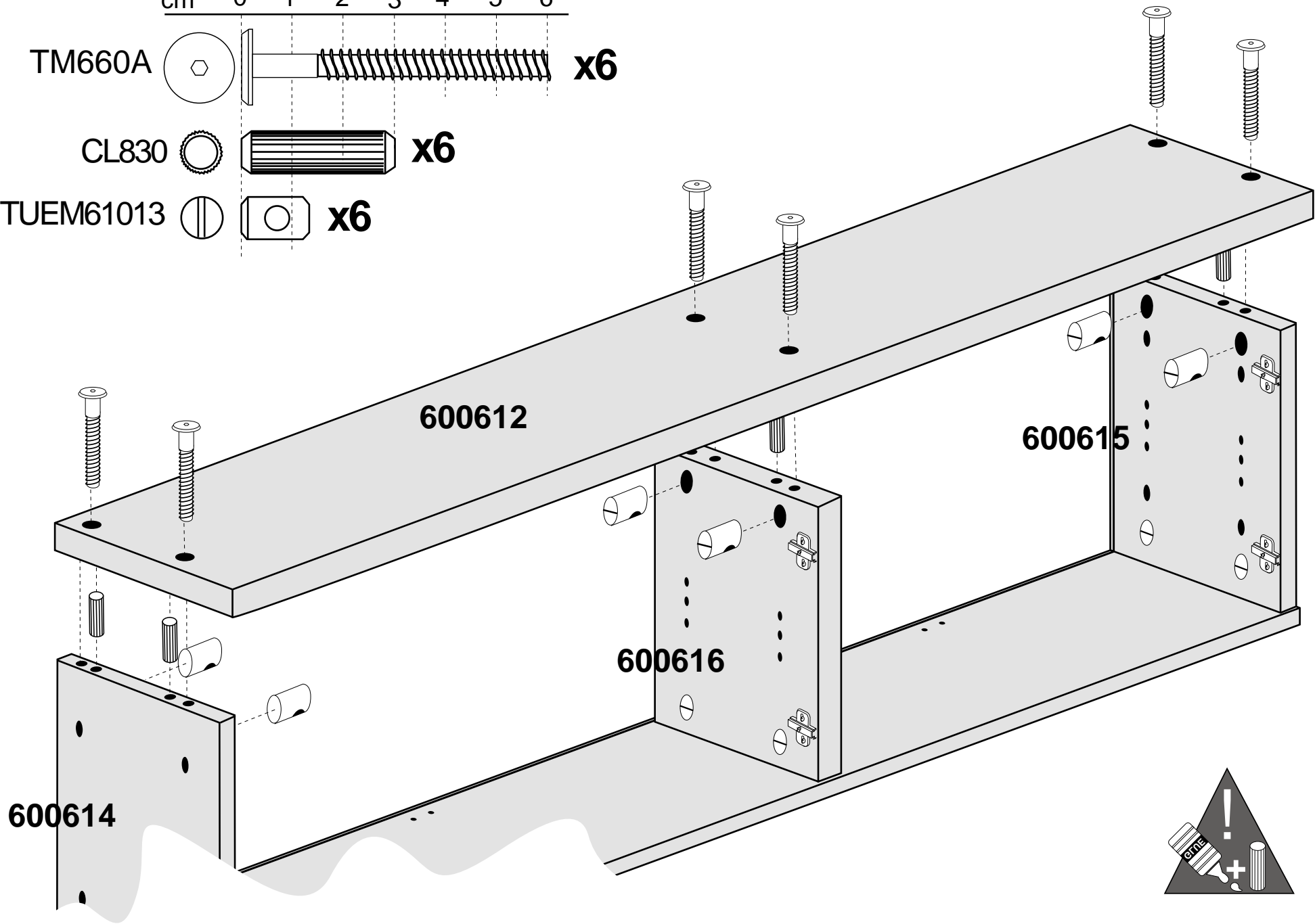

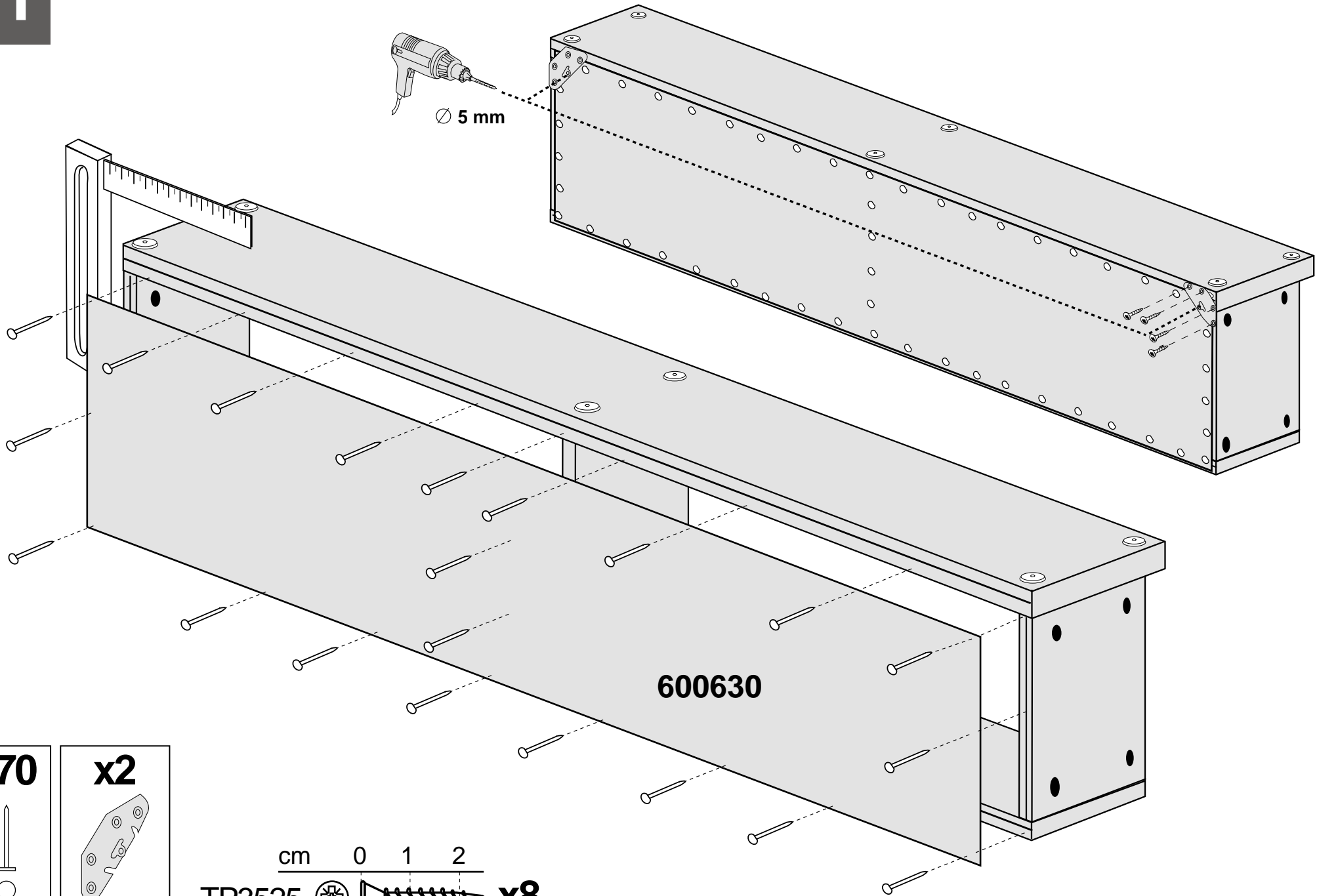
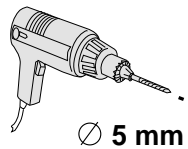

x70



P1010

x2

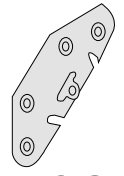

ECG

cm 0 1 2

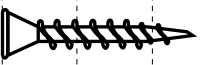

TP3525 **x8**

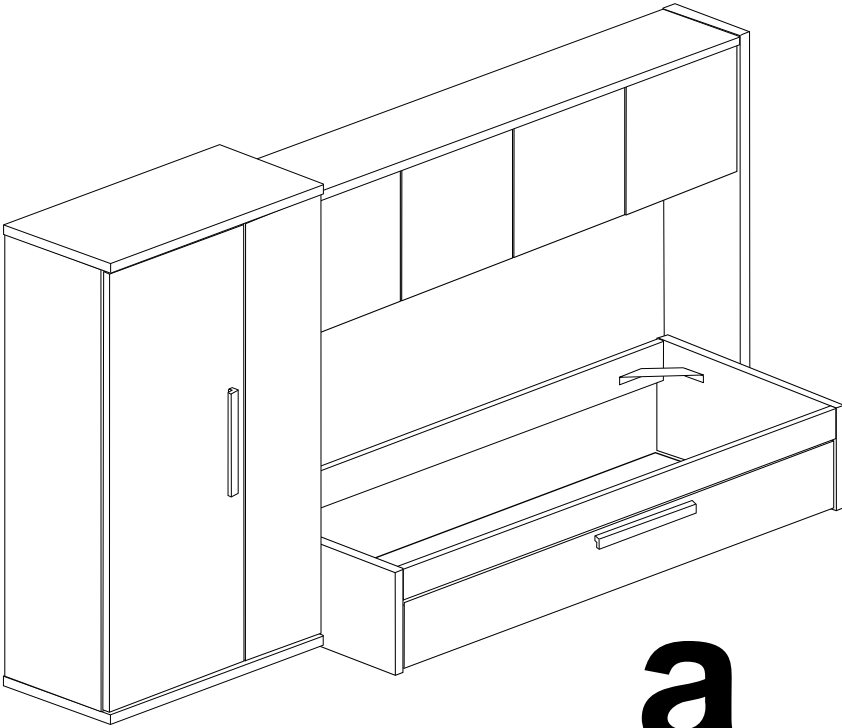

a

?

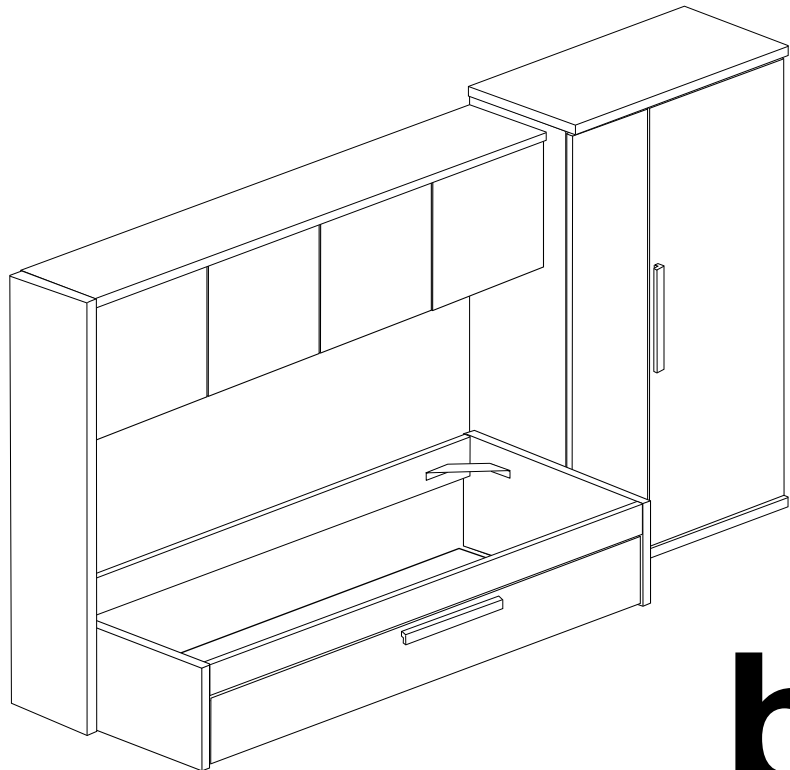

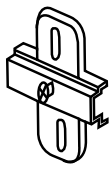

b

12a

x8

BA35S

cm 0 1 2

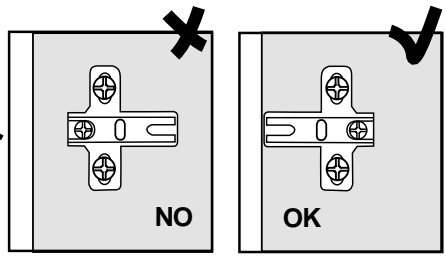
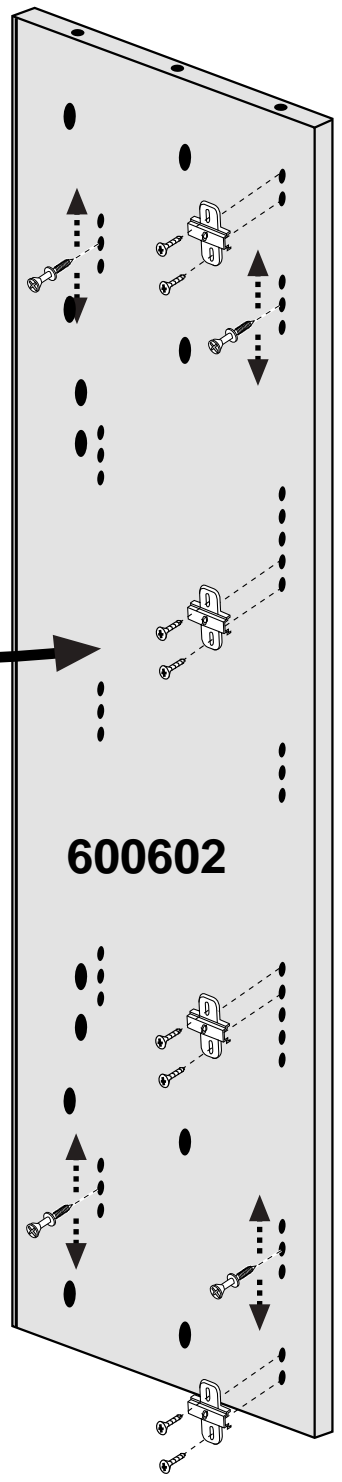
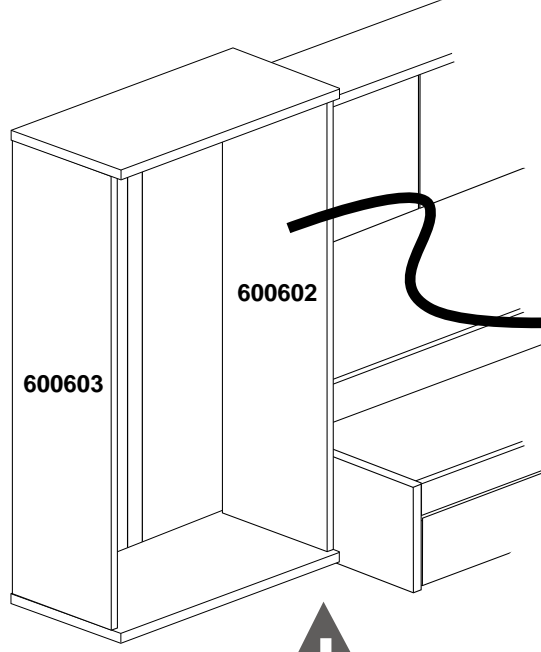
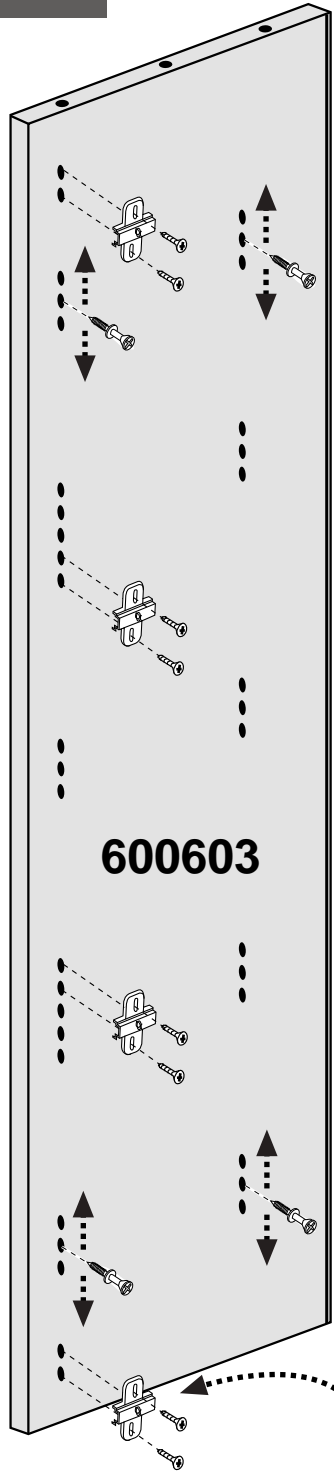
TCK0311  **x8**
TV3135  **x16**

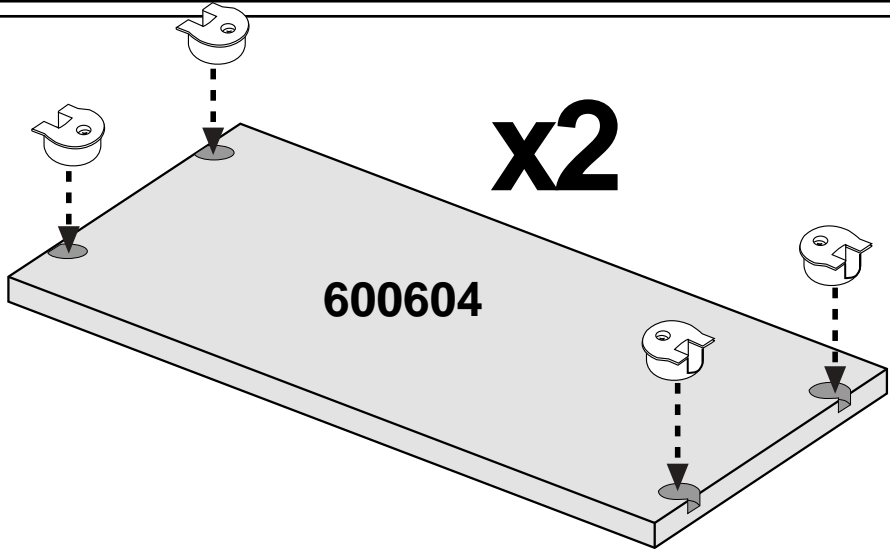

13a

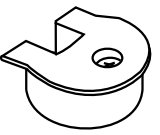

x8

SKM16

14a

cm 0 1 2 3 4 5 6

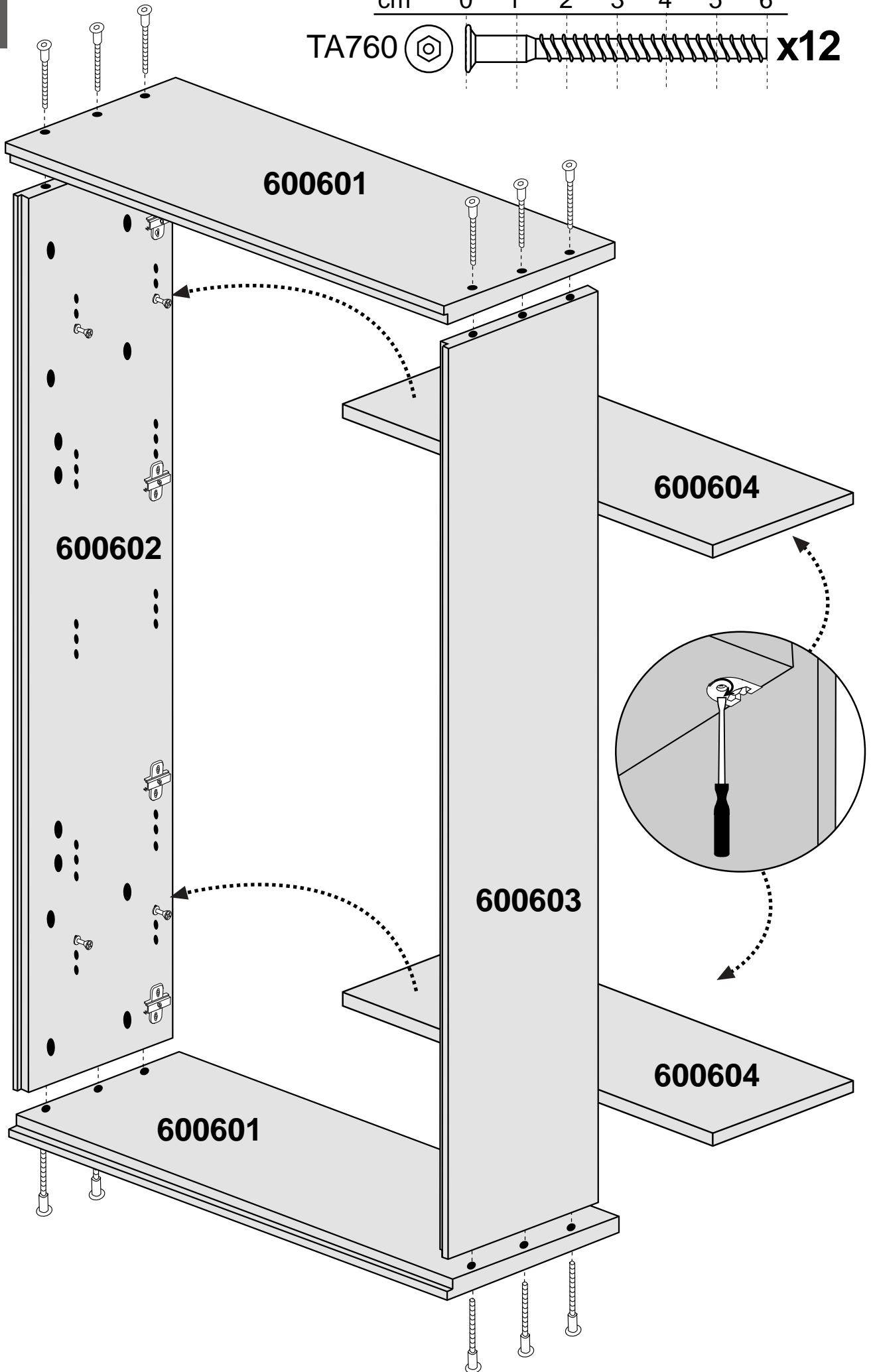
TA760  x12



15a

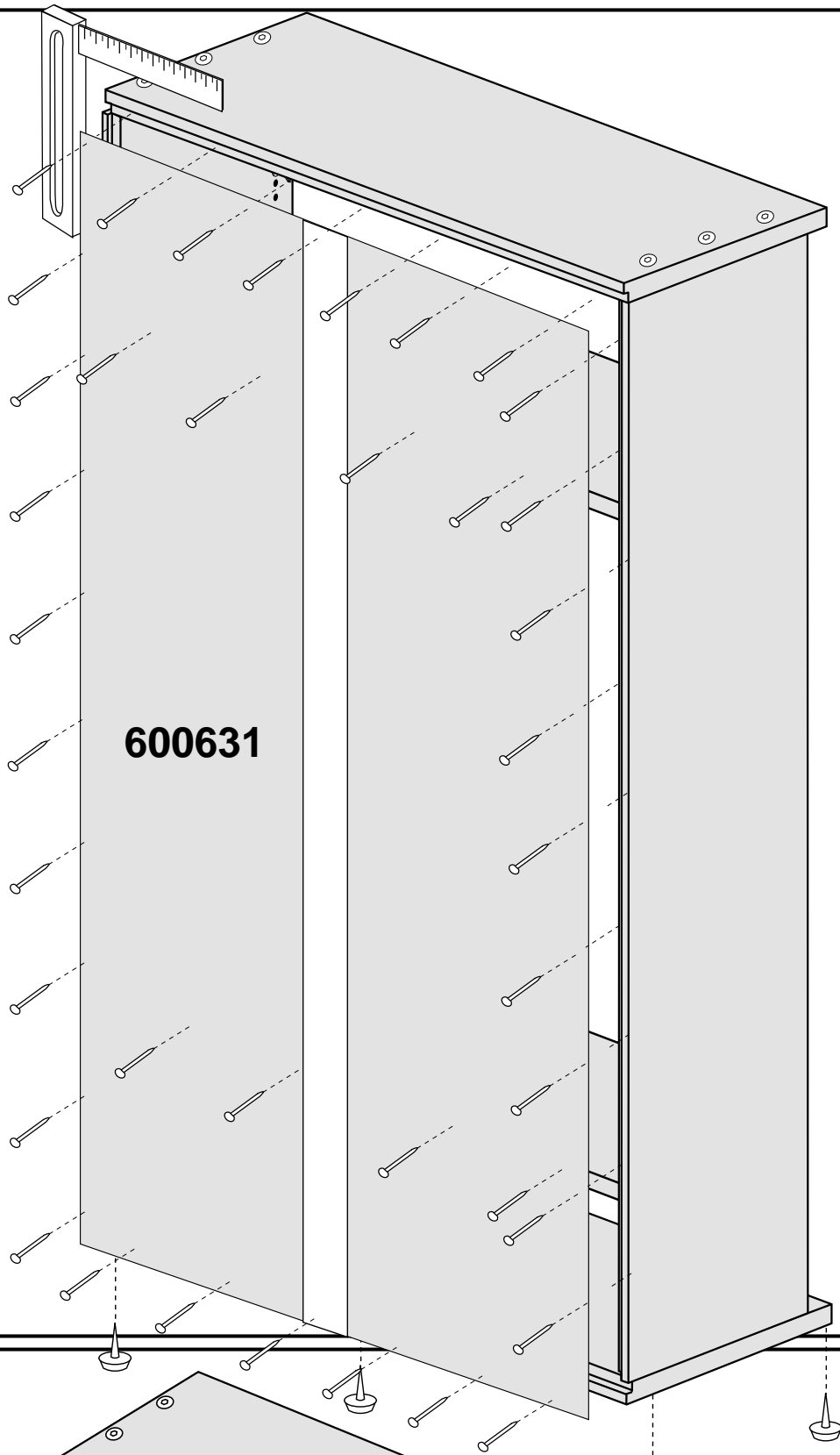

600631

x80



P1010

x6



TSM

16a

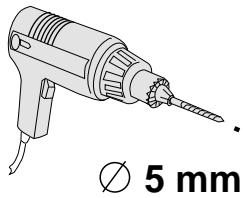

5 mm

cm 0 1 2

TP3525

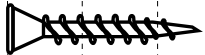

x8

x2

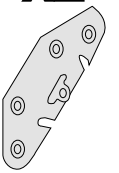

ECG

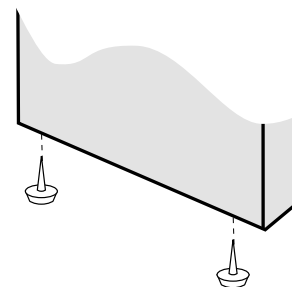
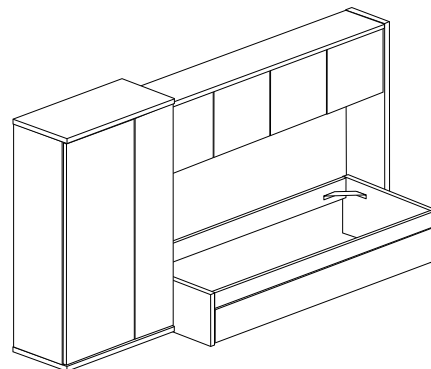
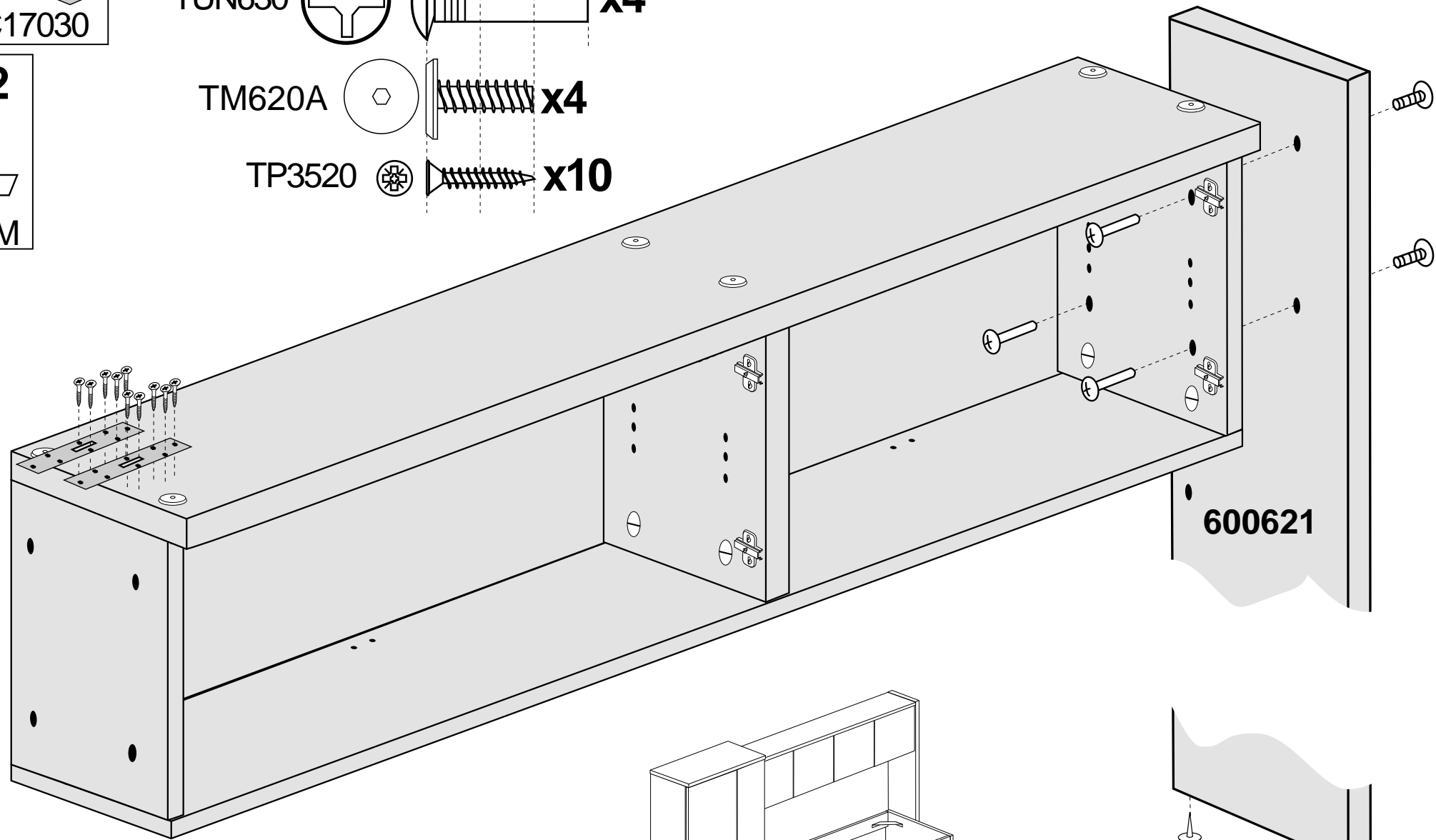
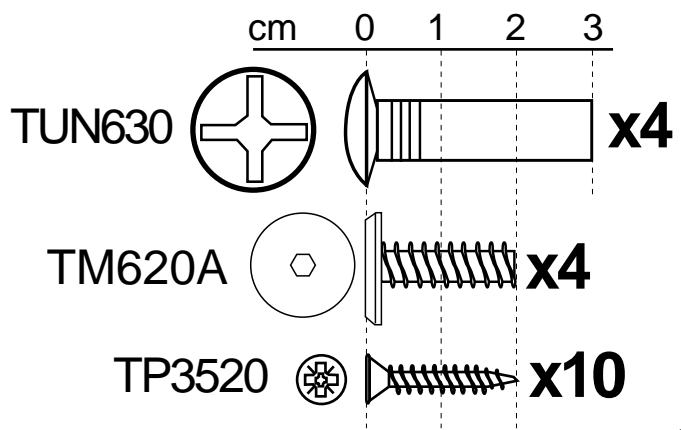
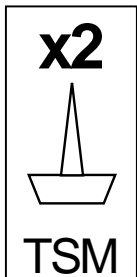
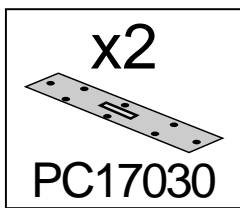

17a

cm 0 1 2 3

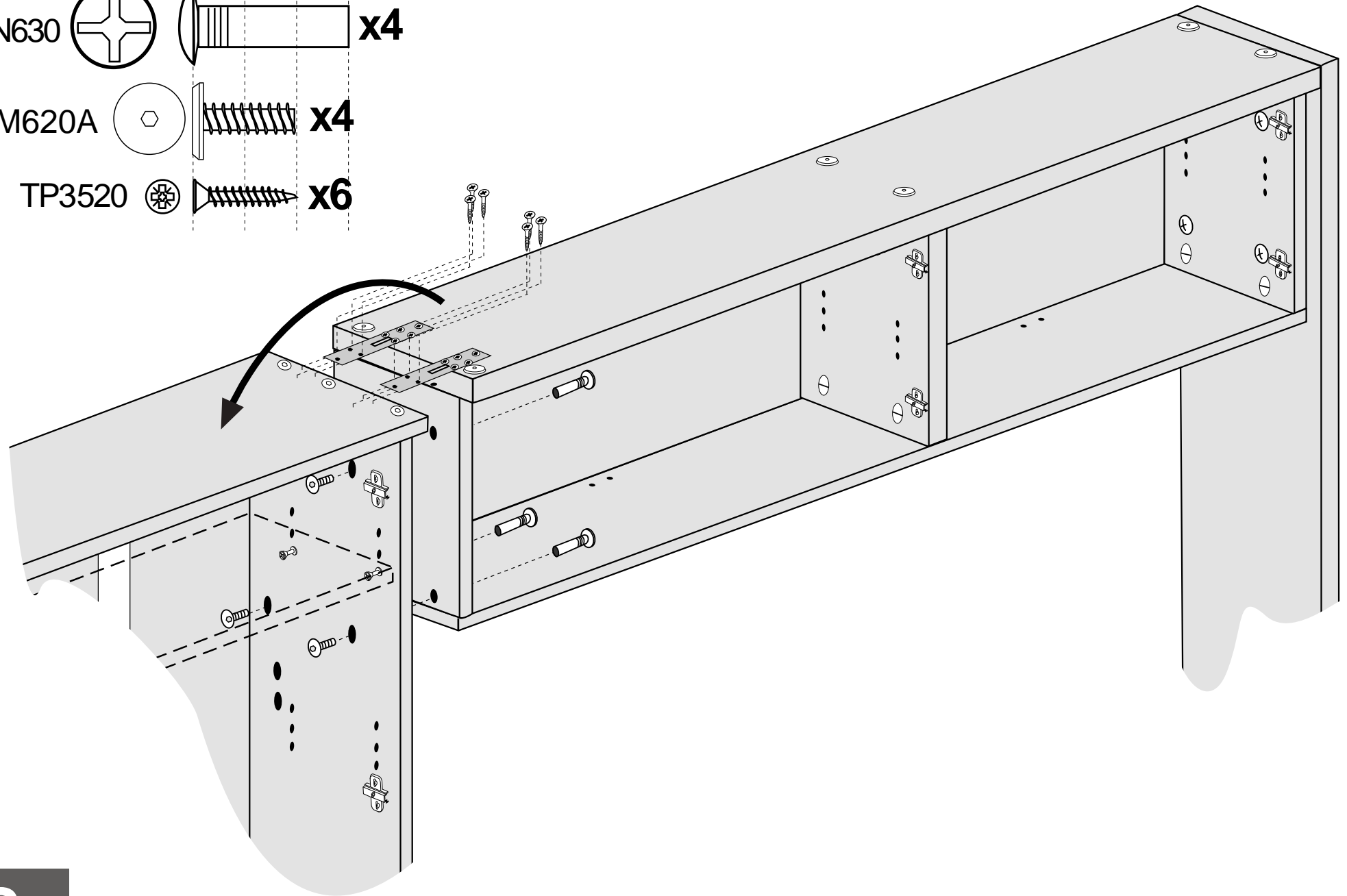
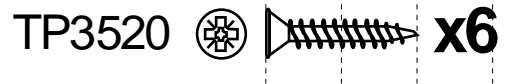
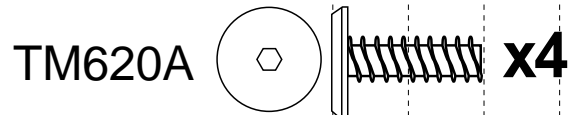
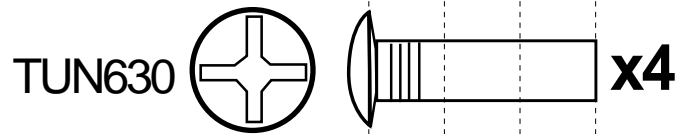

18a

x2

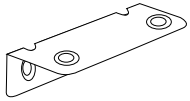

EA2020

cm 0 1 2

TV3135

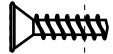

x8

x4



TA4BL

600622

cm 0 1 2 3 4 5 6

TA760

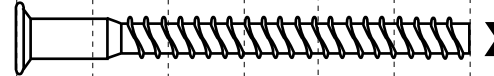

x4

19a

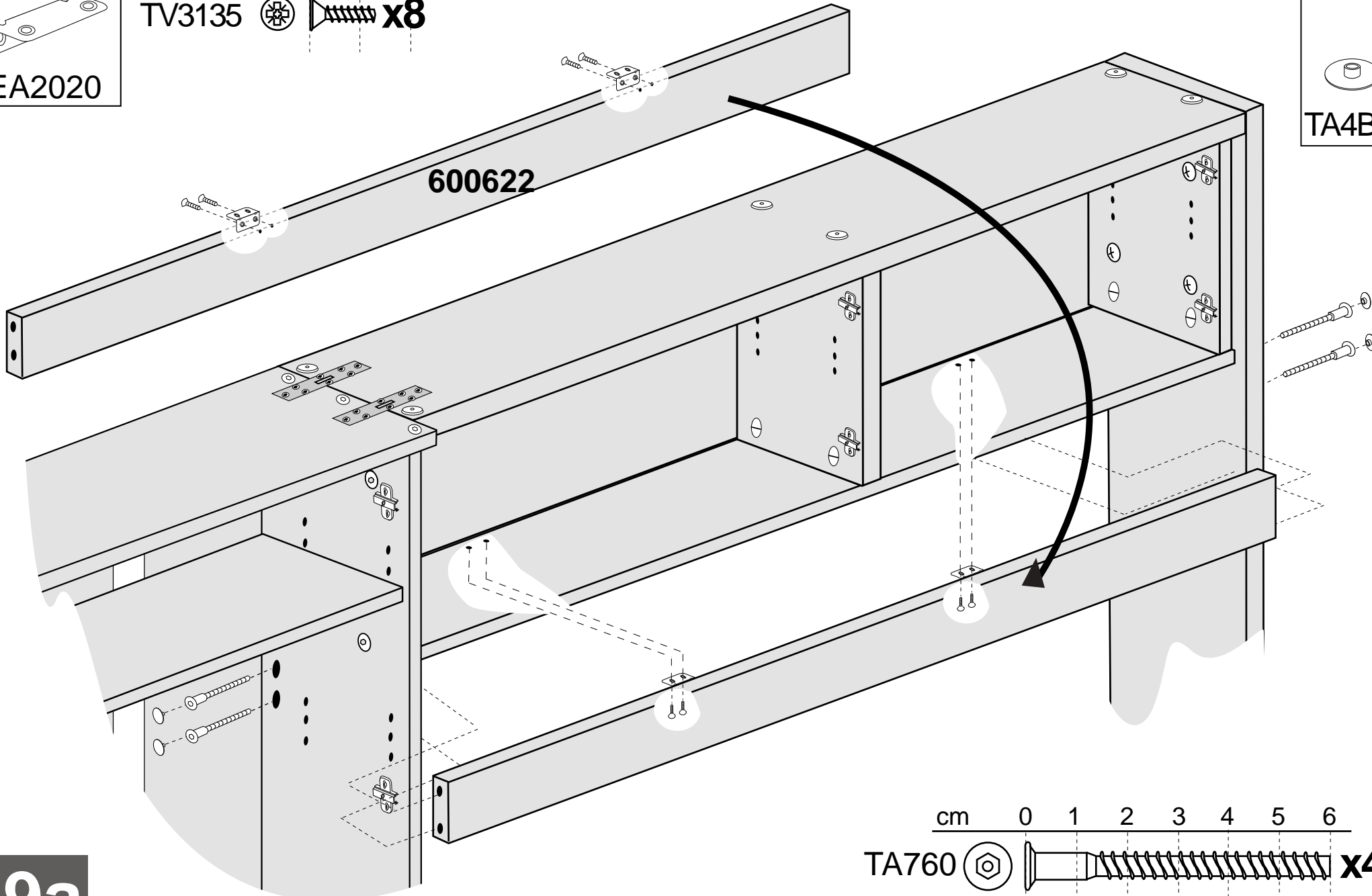

x2



SBO22P

x4

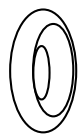

TAPALU

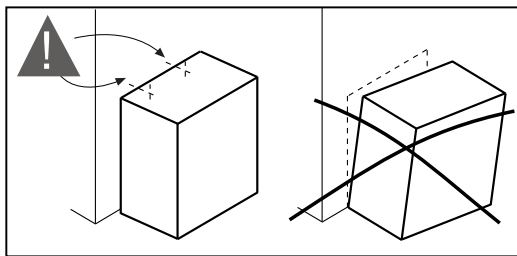

ADVERTENCIA
AVERTISSEMENT
WARNING
AVVERTENZA
ACHTUNG
IMPORTANTE

No incluido
Not included
Pas inclus

No incluido
Not included
Pas inclus

No incluido
Not included
Pas inclus

BA860

250mm

20a

cm 0 1 2
TP3515 x4

x1



BA860

21a

cm 0 1 2 3
TP3535  x4

x8

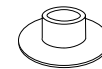

T8BL

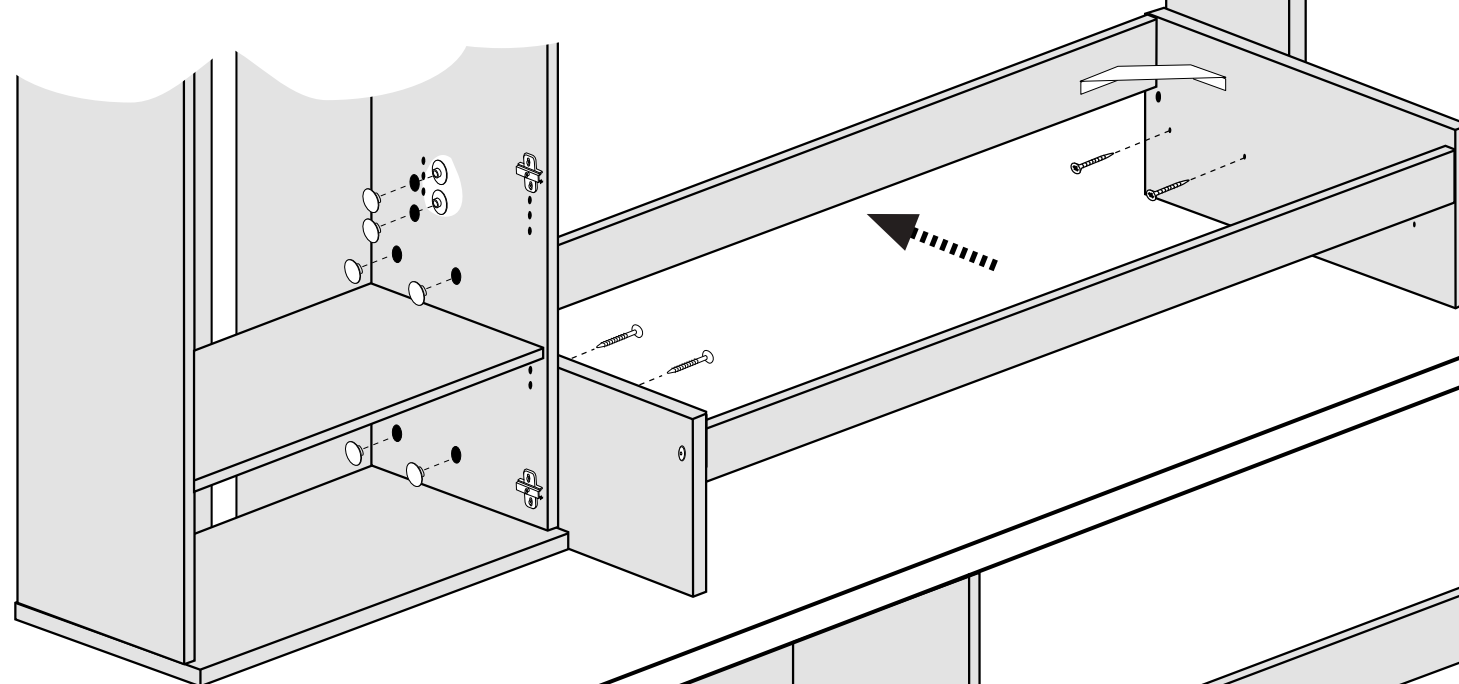

22a

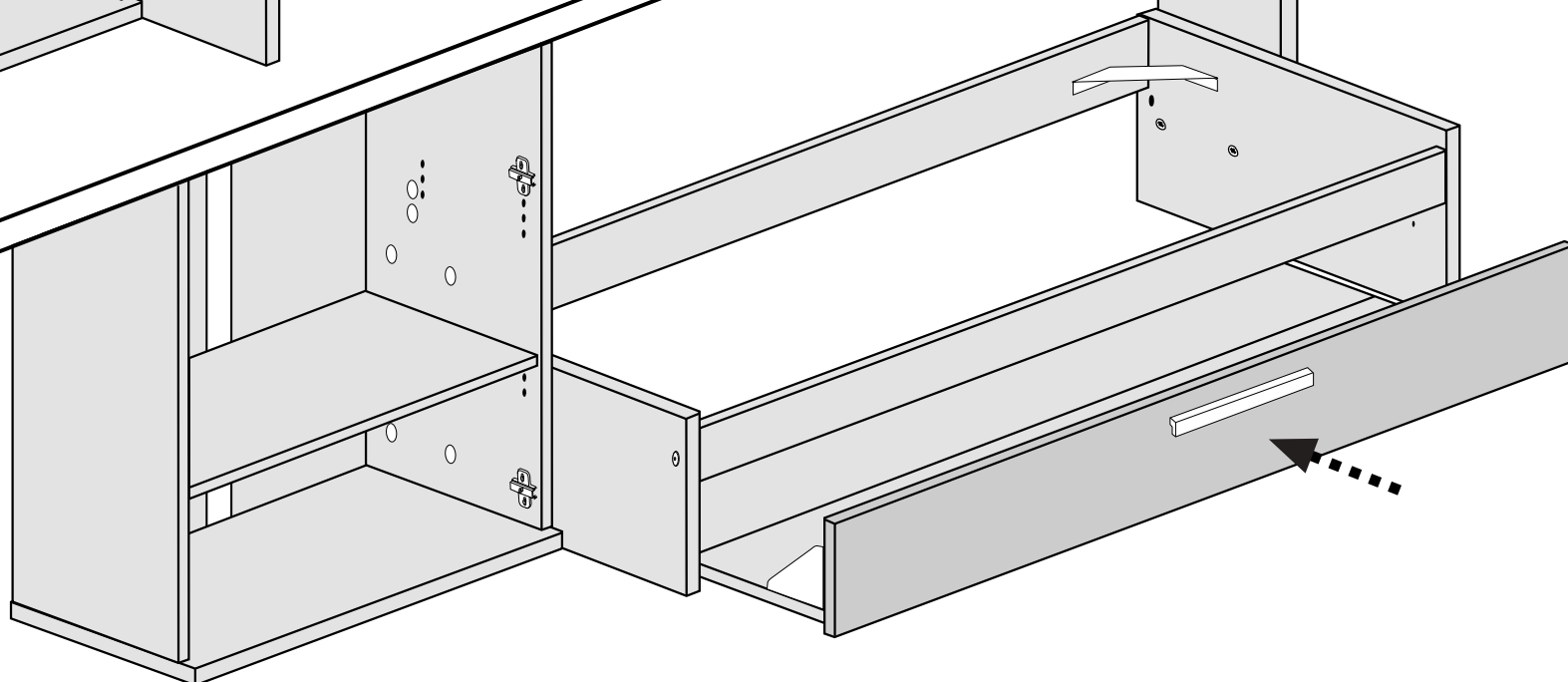

23a

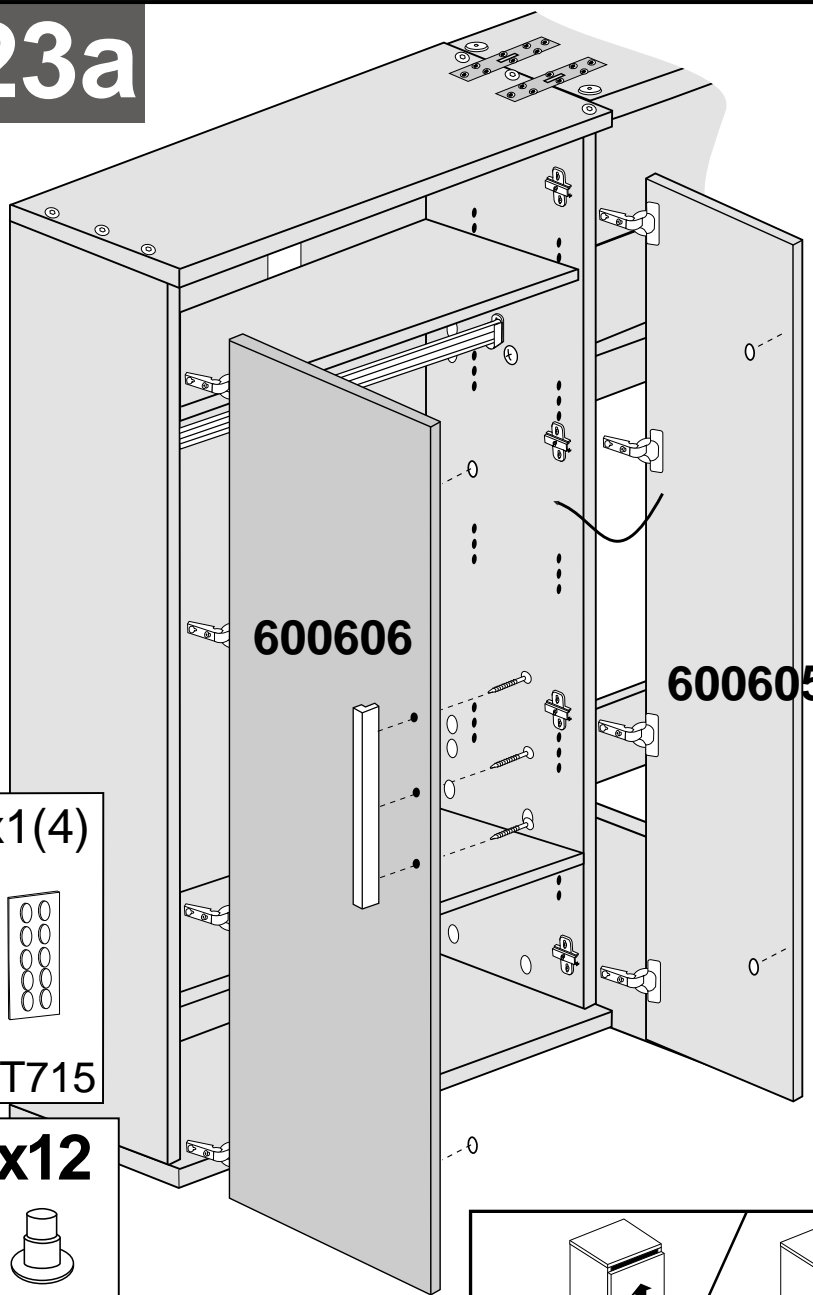

x1(4)

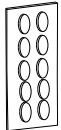

CT715

x12



T5PC

x1



AAB400

x3



TCA4030

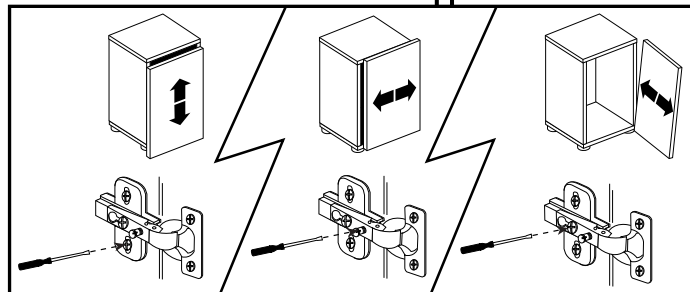

x8

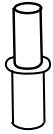

PE3

x1(4)



CT715

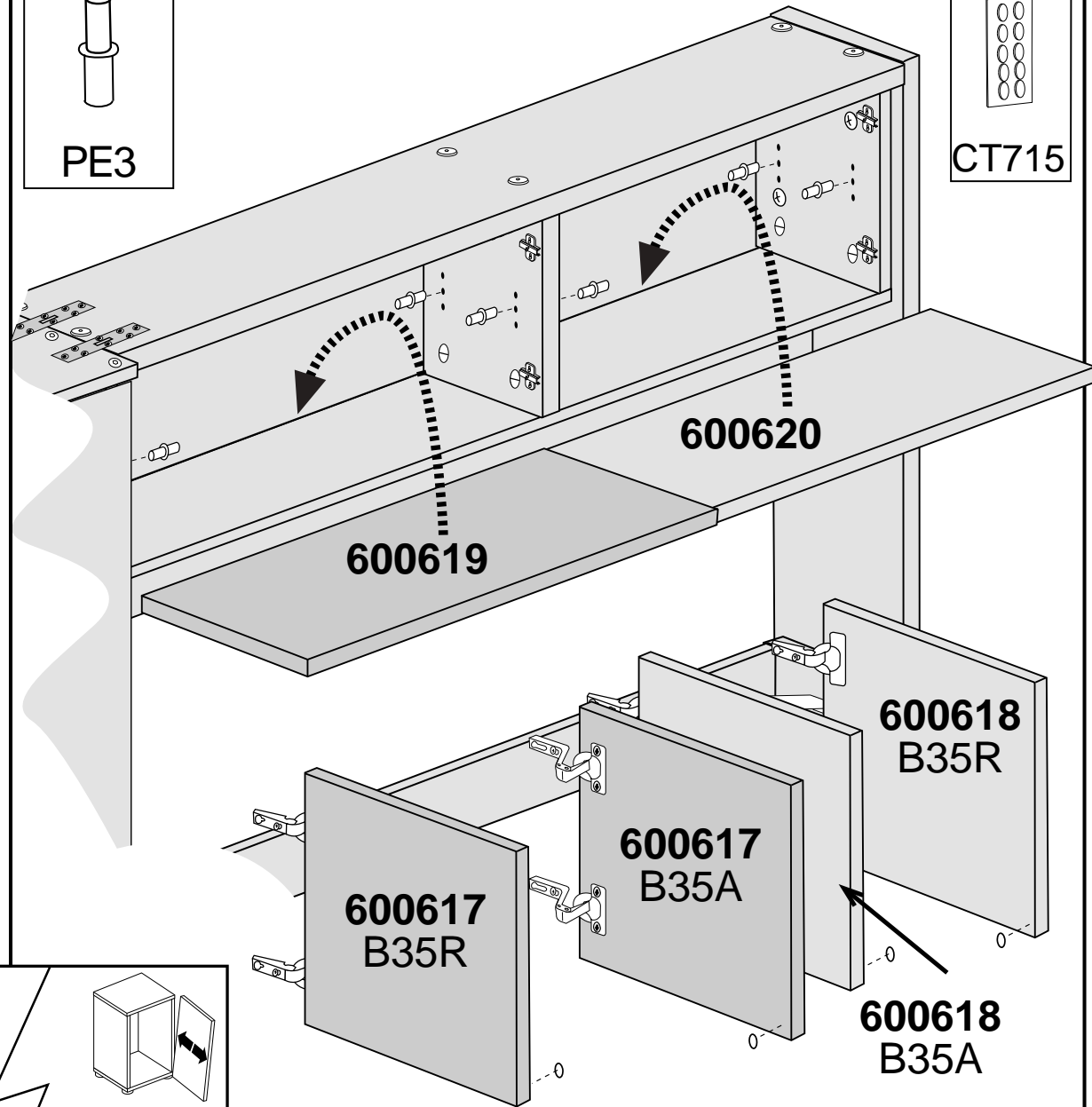

24a

25a

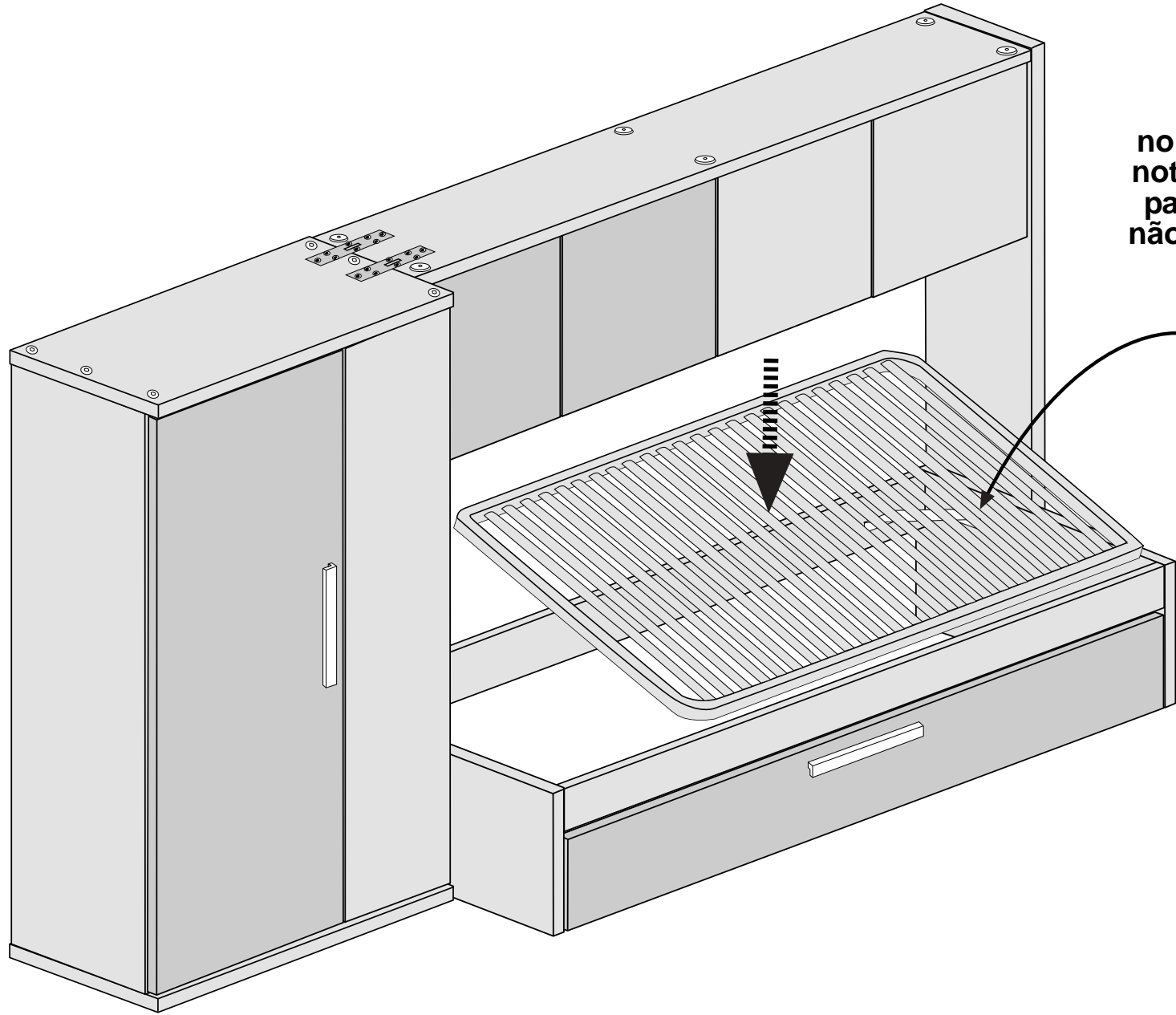

no incluido
not included
pas inclus
não incluído

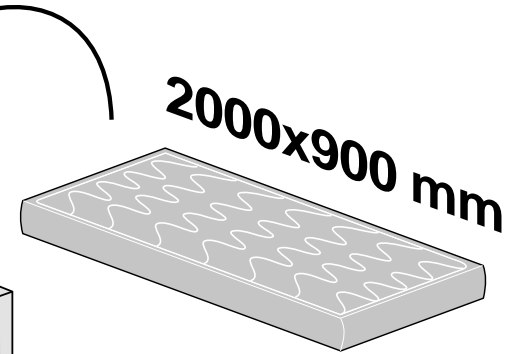

2000x900 mm

12b

cm 0 1 2

TCK0311  **x8**

TV3135  **x16**

x8

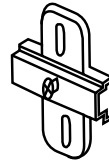

BA35S

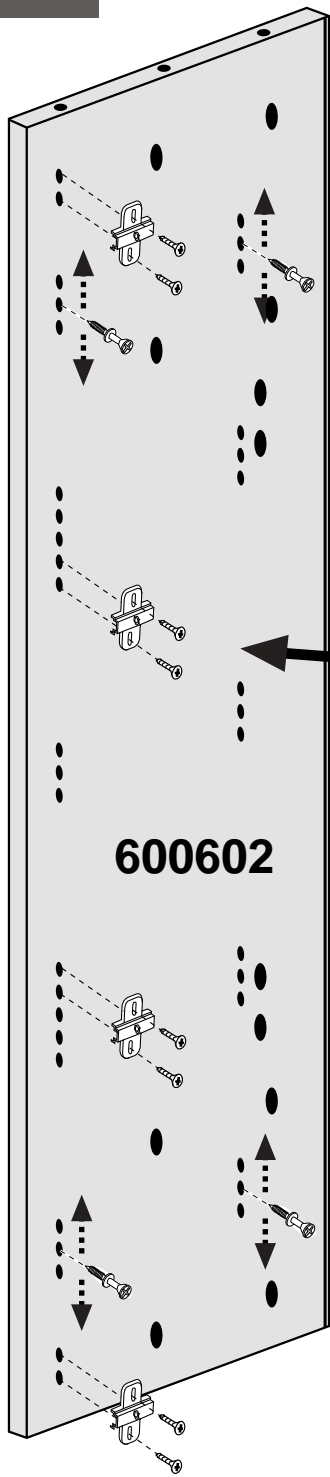

600602

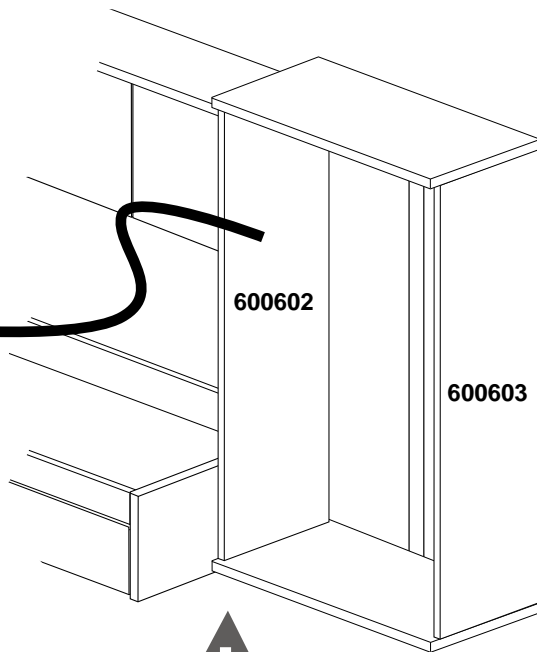

600602

600603

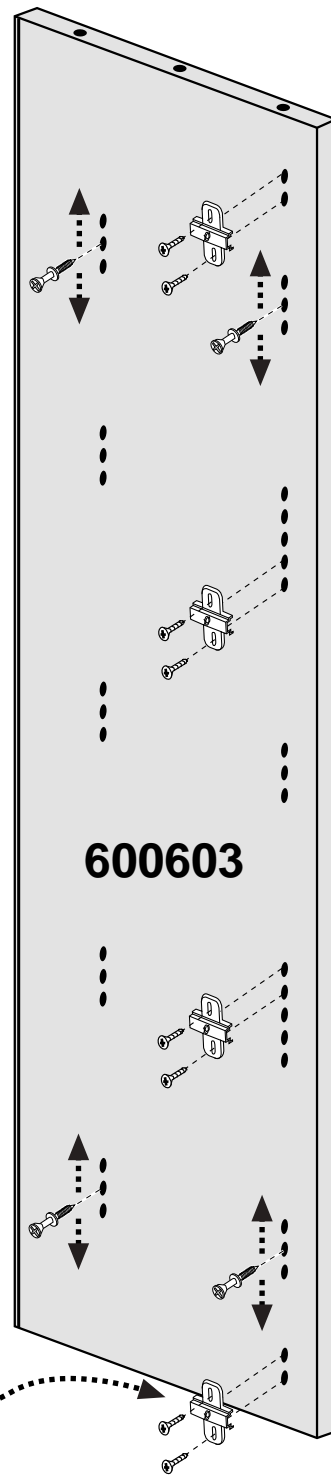

600603

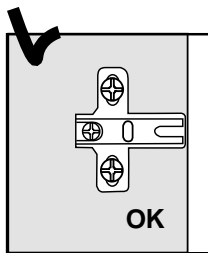

OK

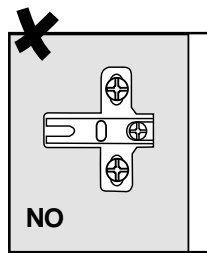

NO

13b

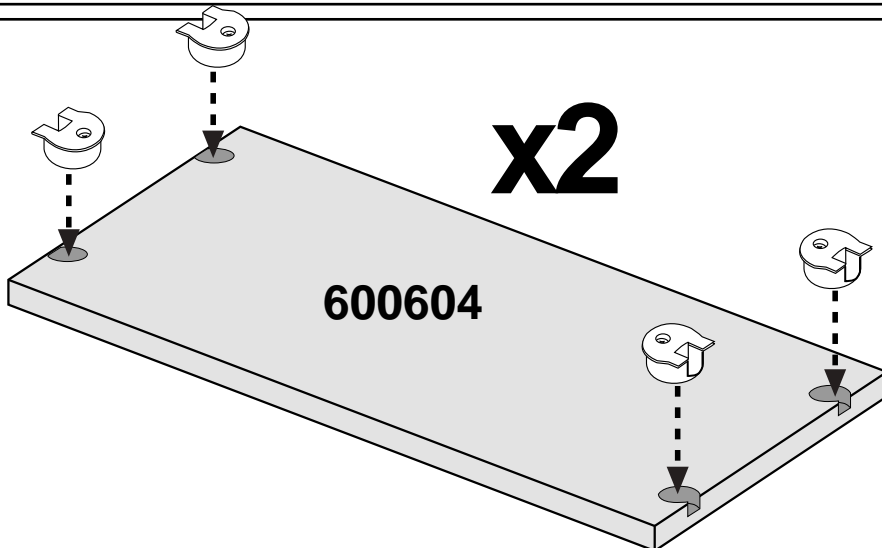

600604

x2

x8

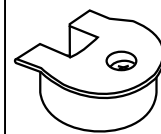

SKM16

cm 0 1 2 3 4 5 6

TA760  x12

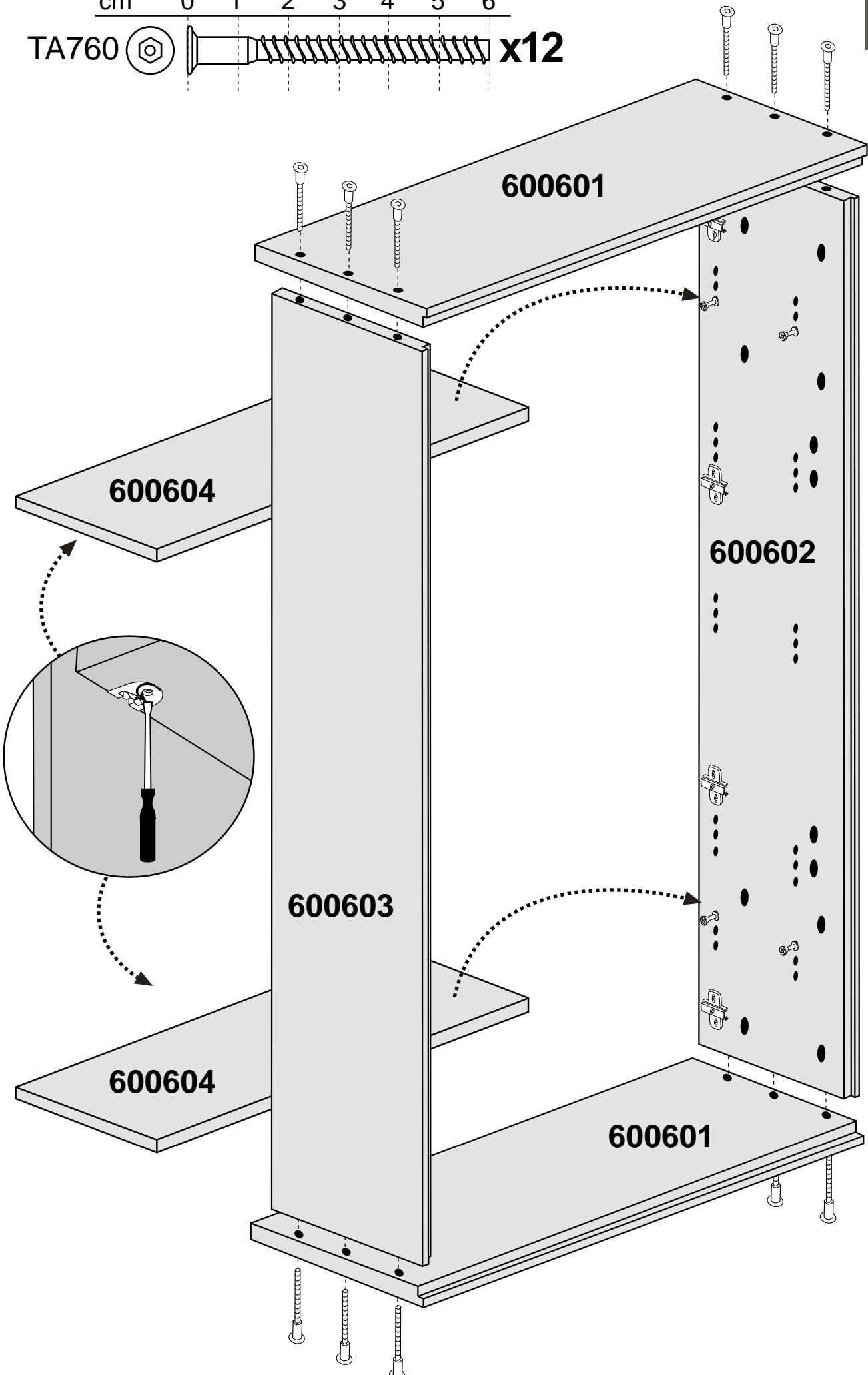

15b

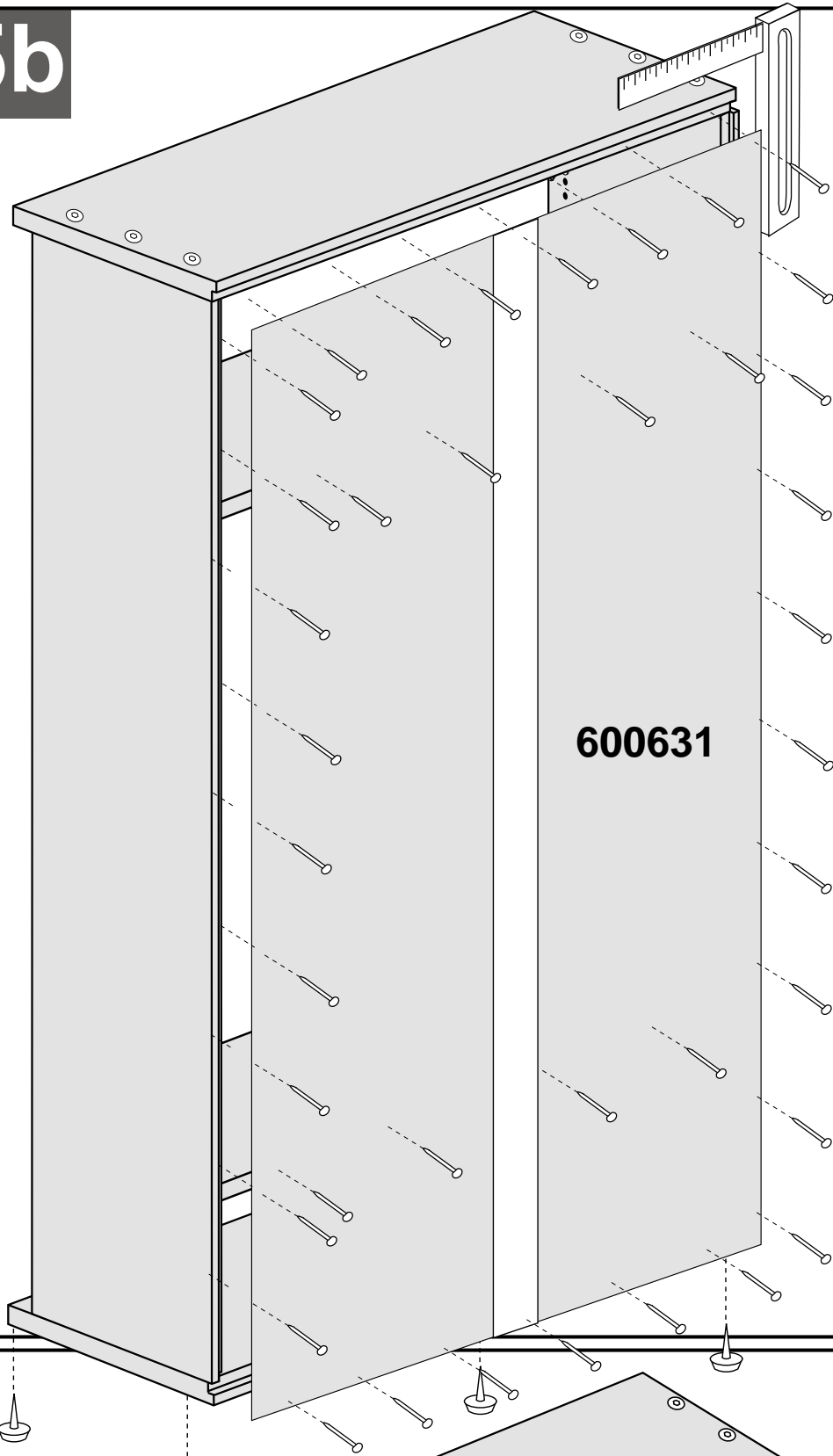

600631



x80

P1010

x6

TSM

16b

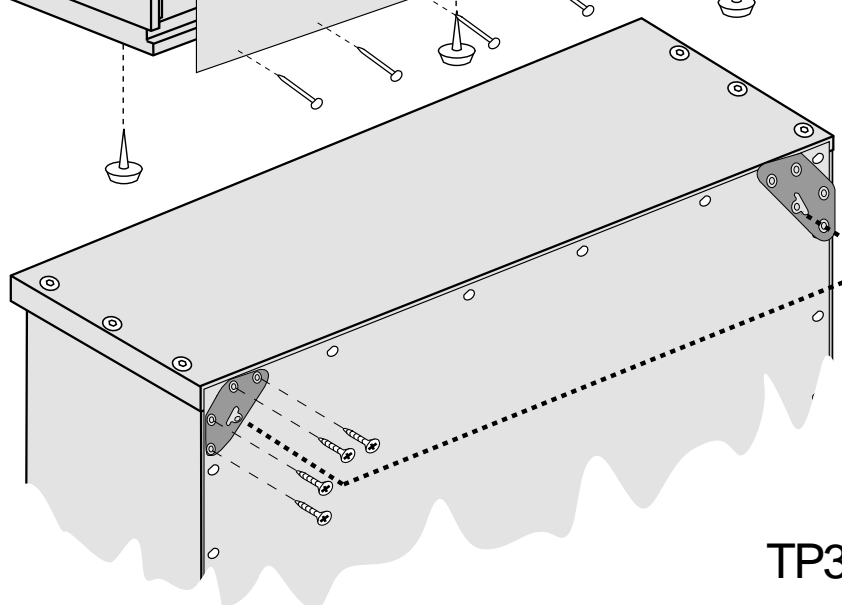

5 mm

cm 0 1 2

TP3525 **x8**

x2

ECG

cm 0 1 2 3

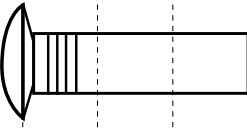
TUN630   **x4**

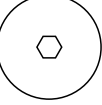
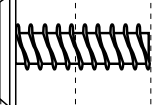
TM620A   **x4**

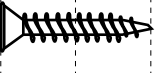
TP3520   **x10**

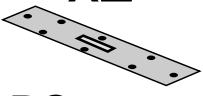
x2

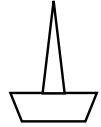
PC17030

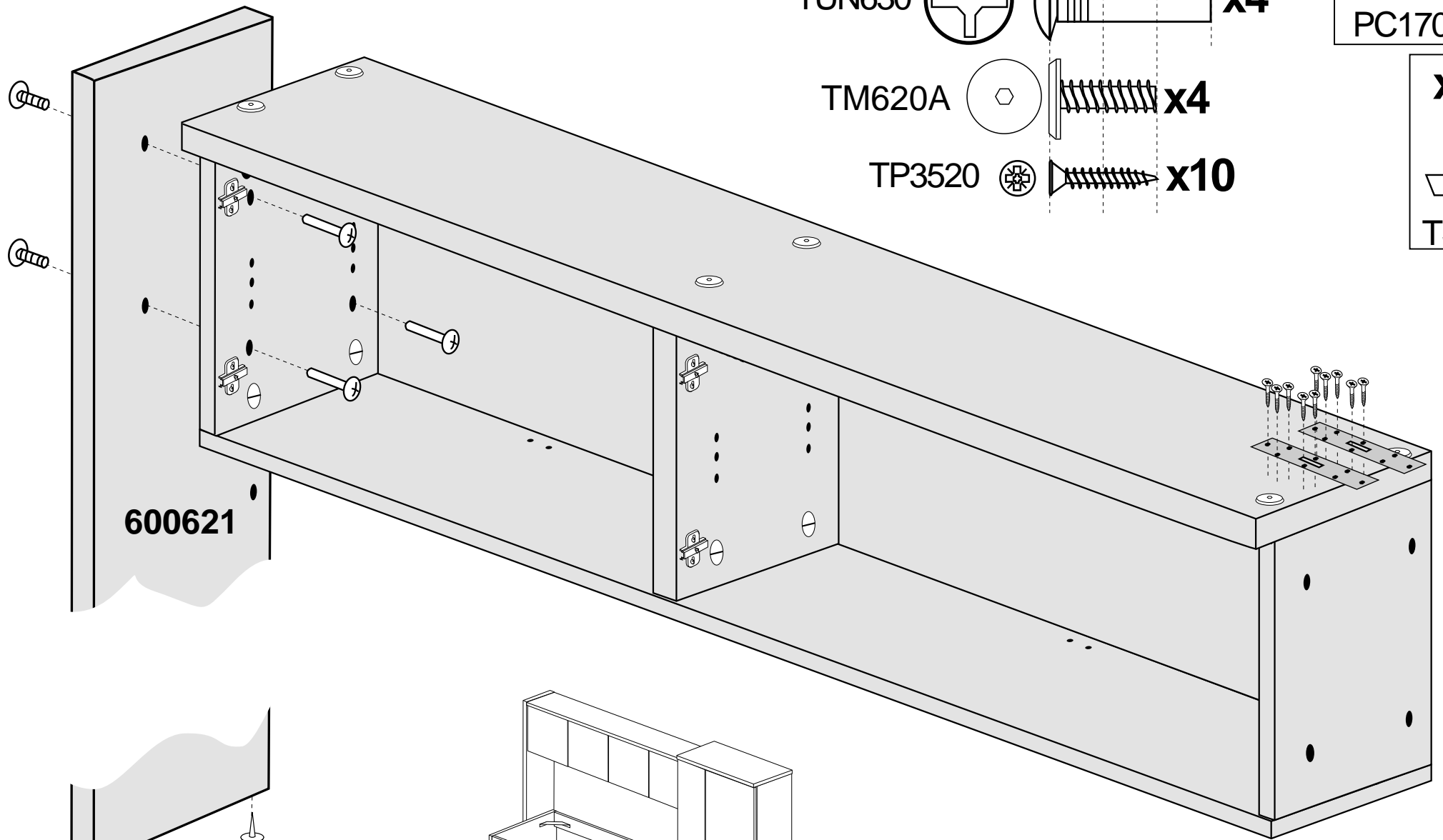
x2

TSM

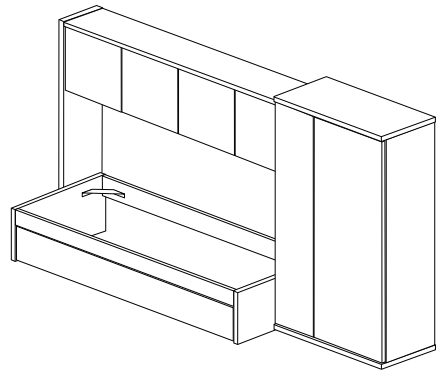
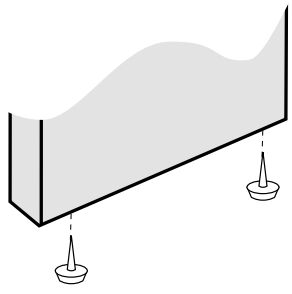

600621

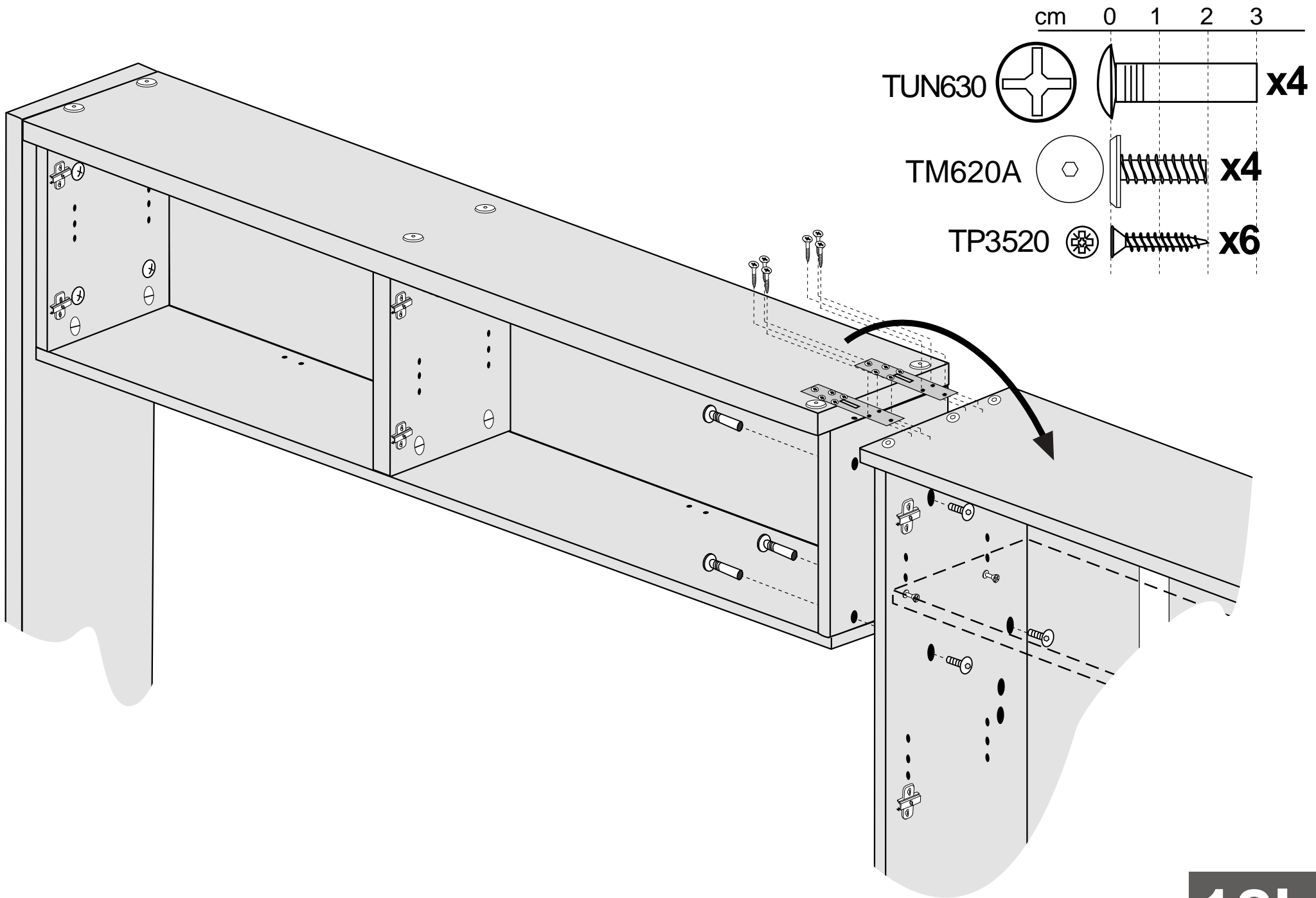

17b



18b

x4



TA4BL

cm 0 1 2

TV3135 x8

x2

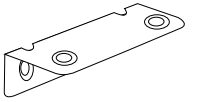

EA2020

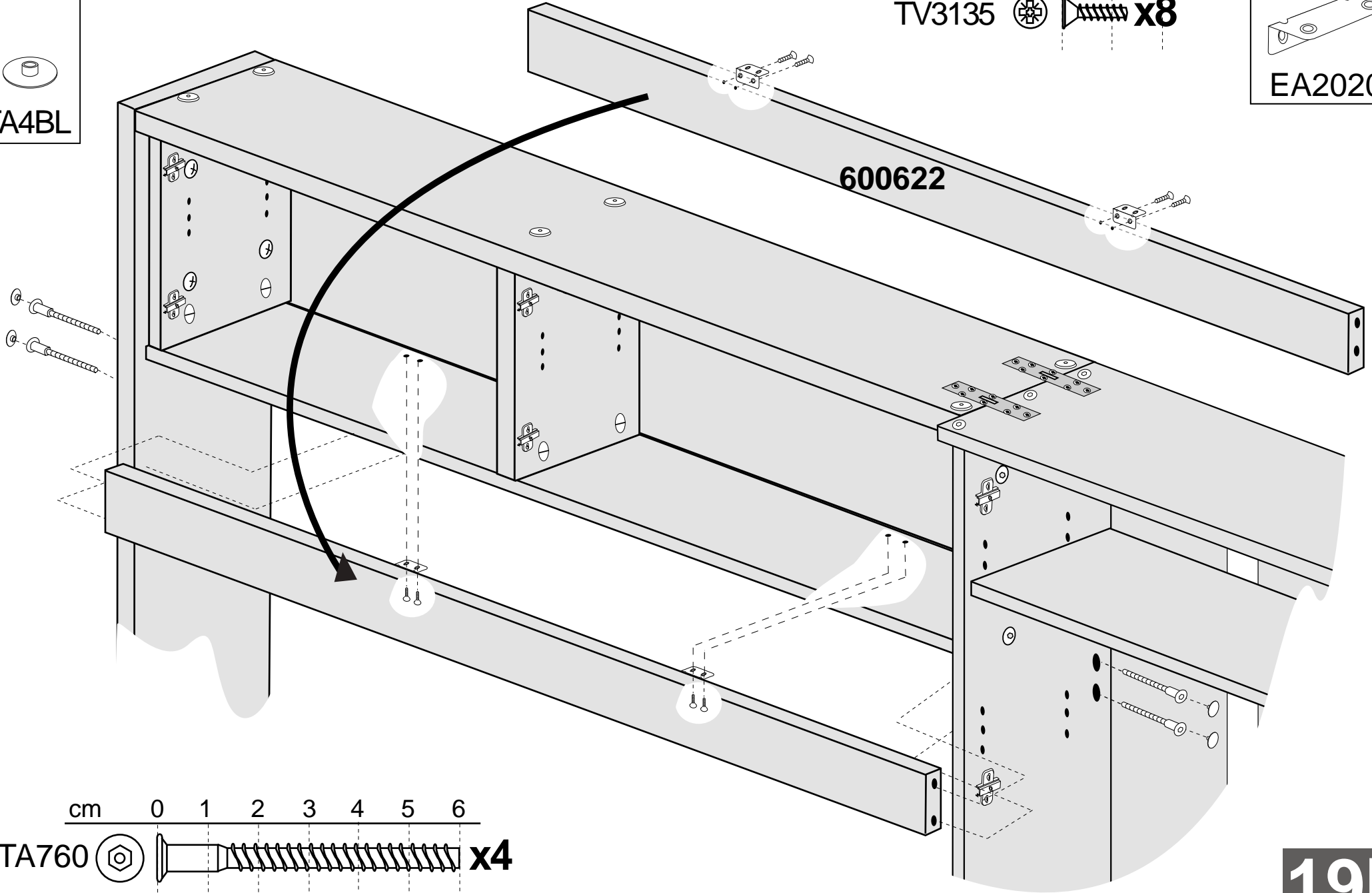

ADVERTENCIA
AVERTISSEMENT
WARNING
AVVERTENZA
ACHTUNG
IMPORTANTE

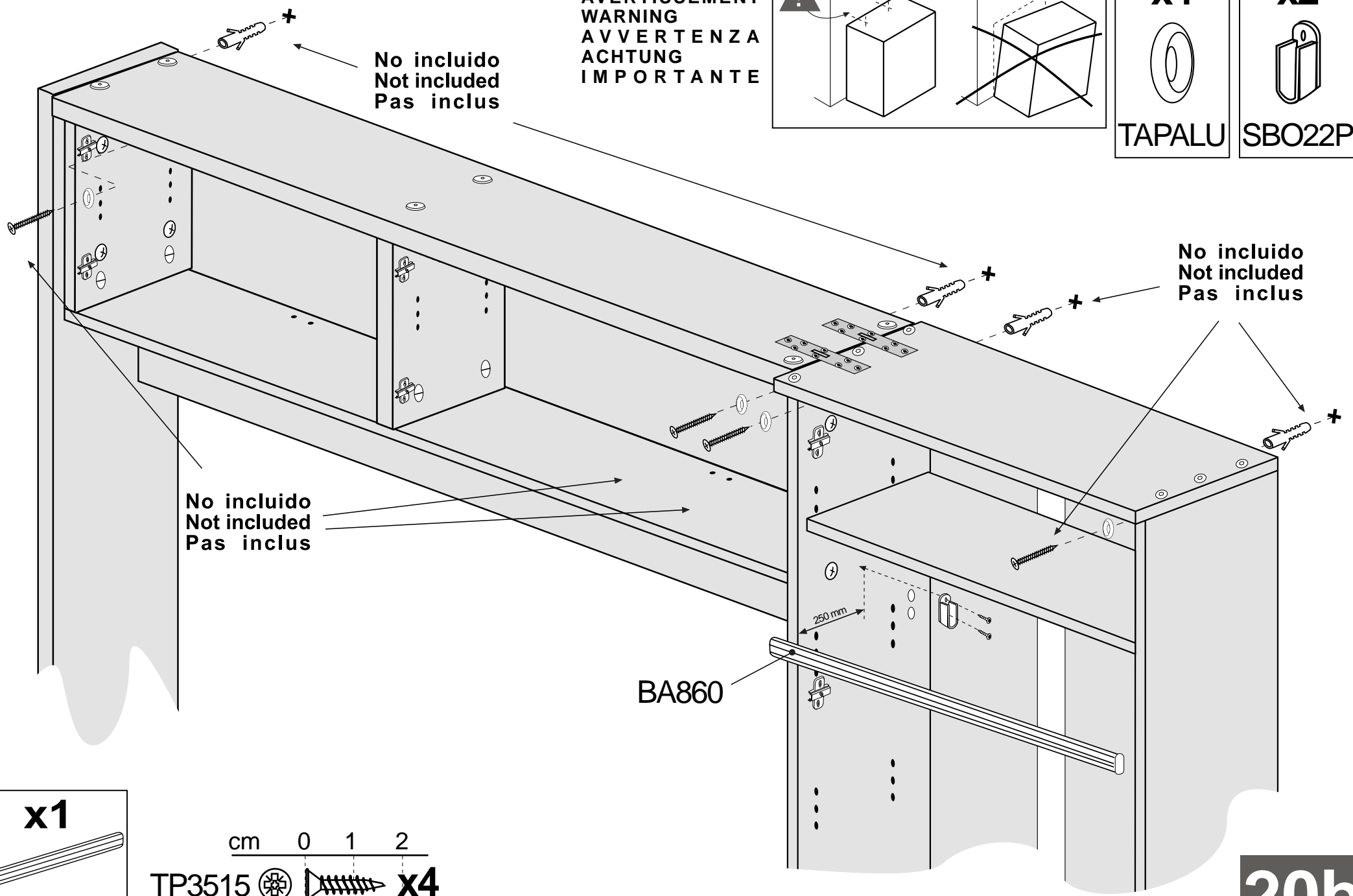
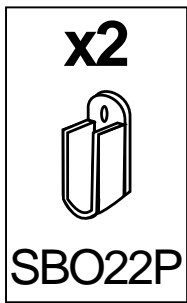
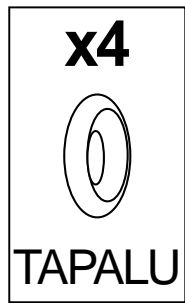
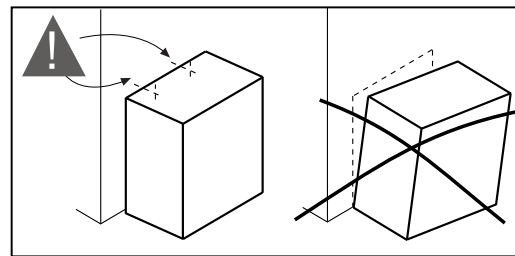

No incluido
Not included
Pas inclus

No incluido
Not included
Pas inclus

No incluido
Not included
Pas inclus

BA860

250 mm

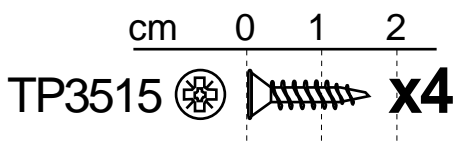
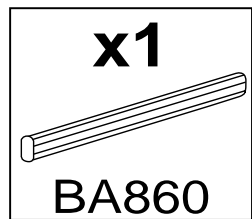

20b

x8

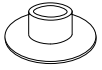

T8BL

cm 0 1 2 3
TP3535  x4

21b

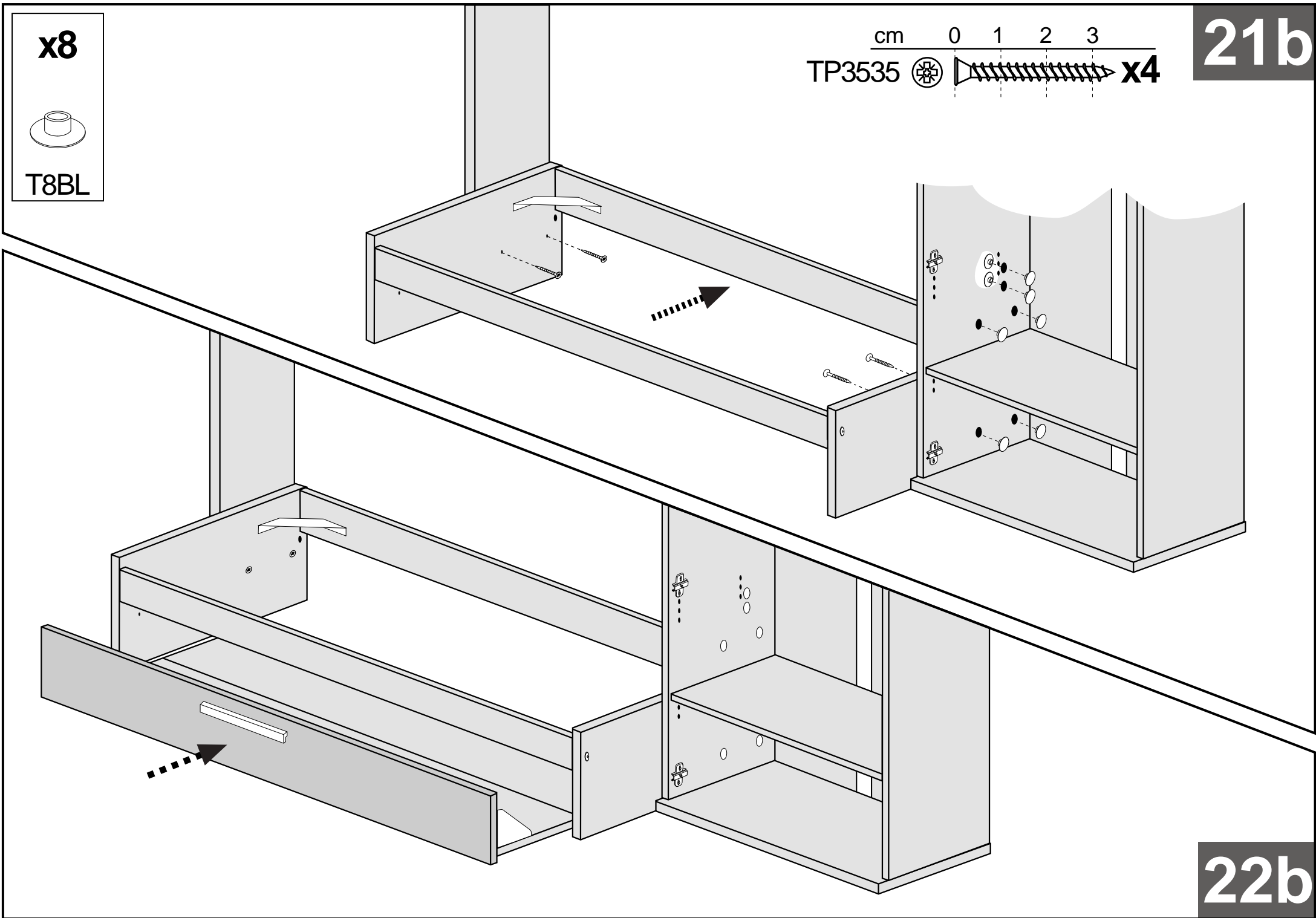

22b

23b

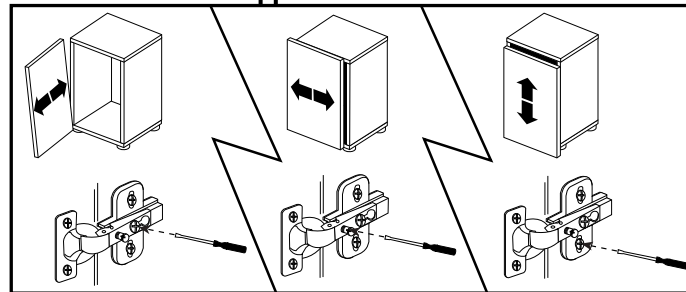
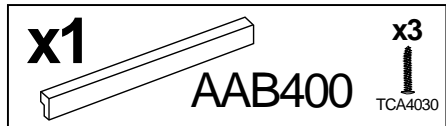
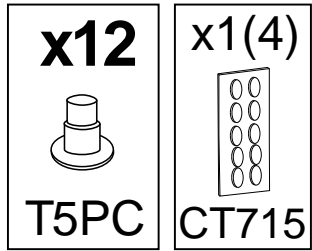
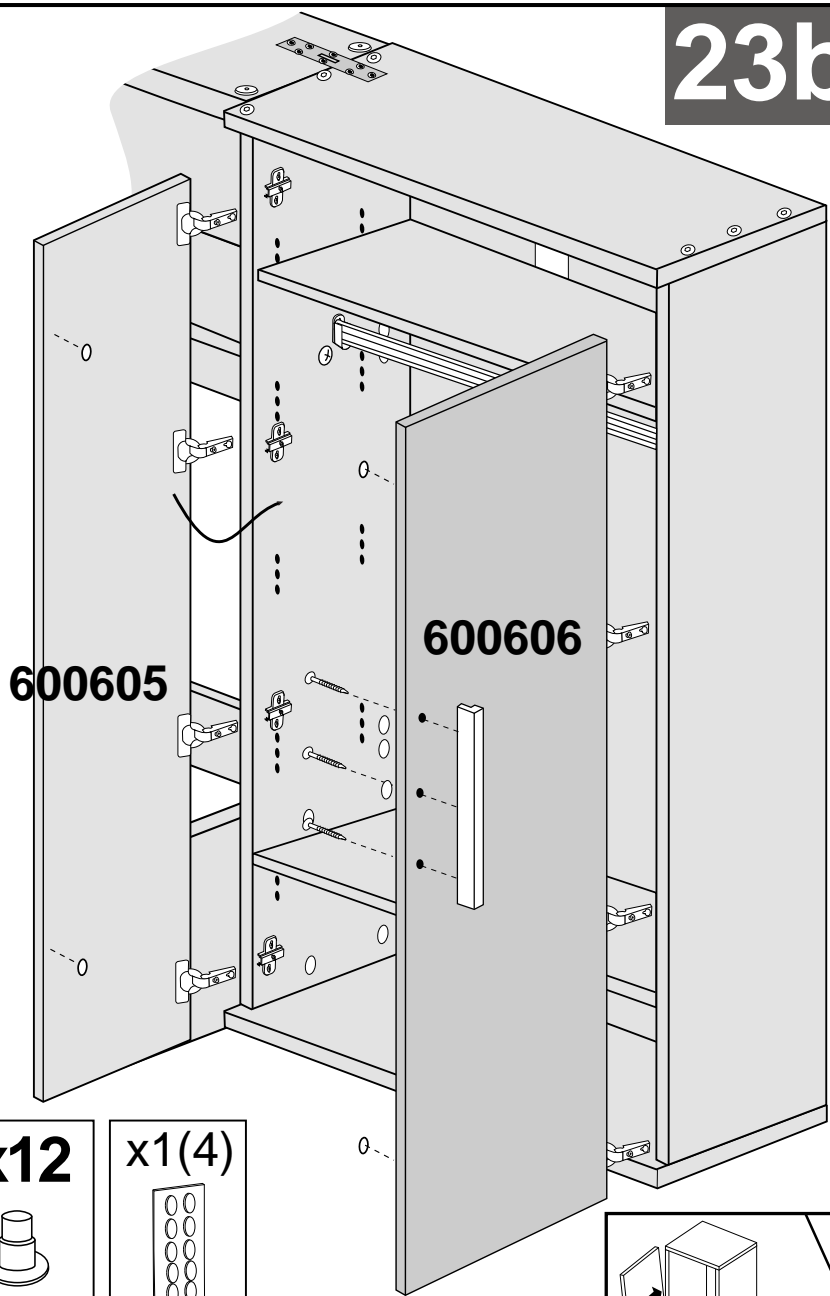

24b

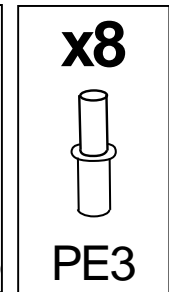
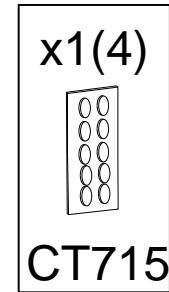
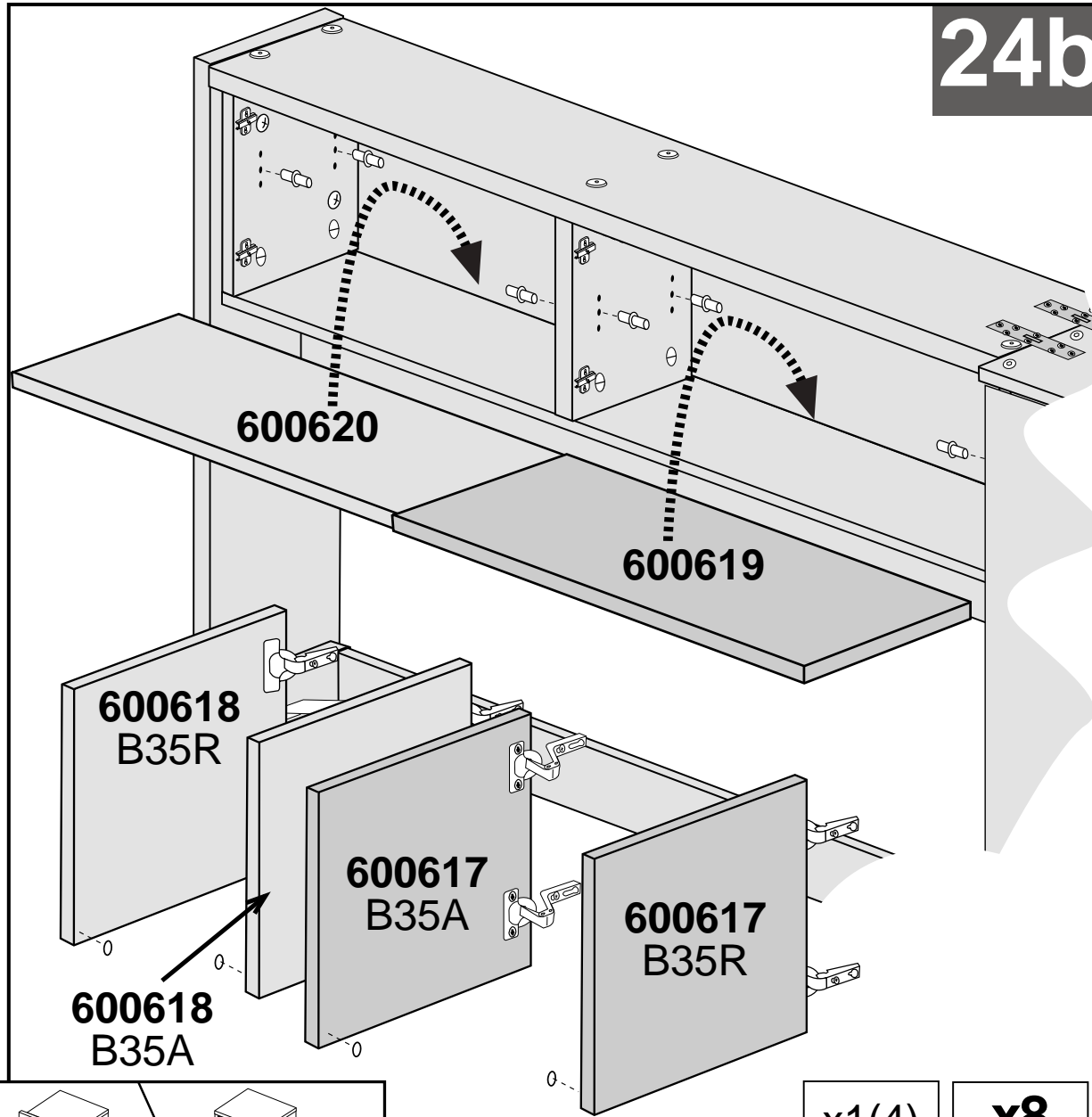

25b

no incluido
not included
pas inclus
não incluído

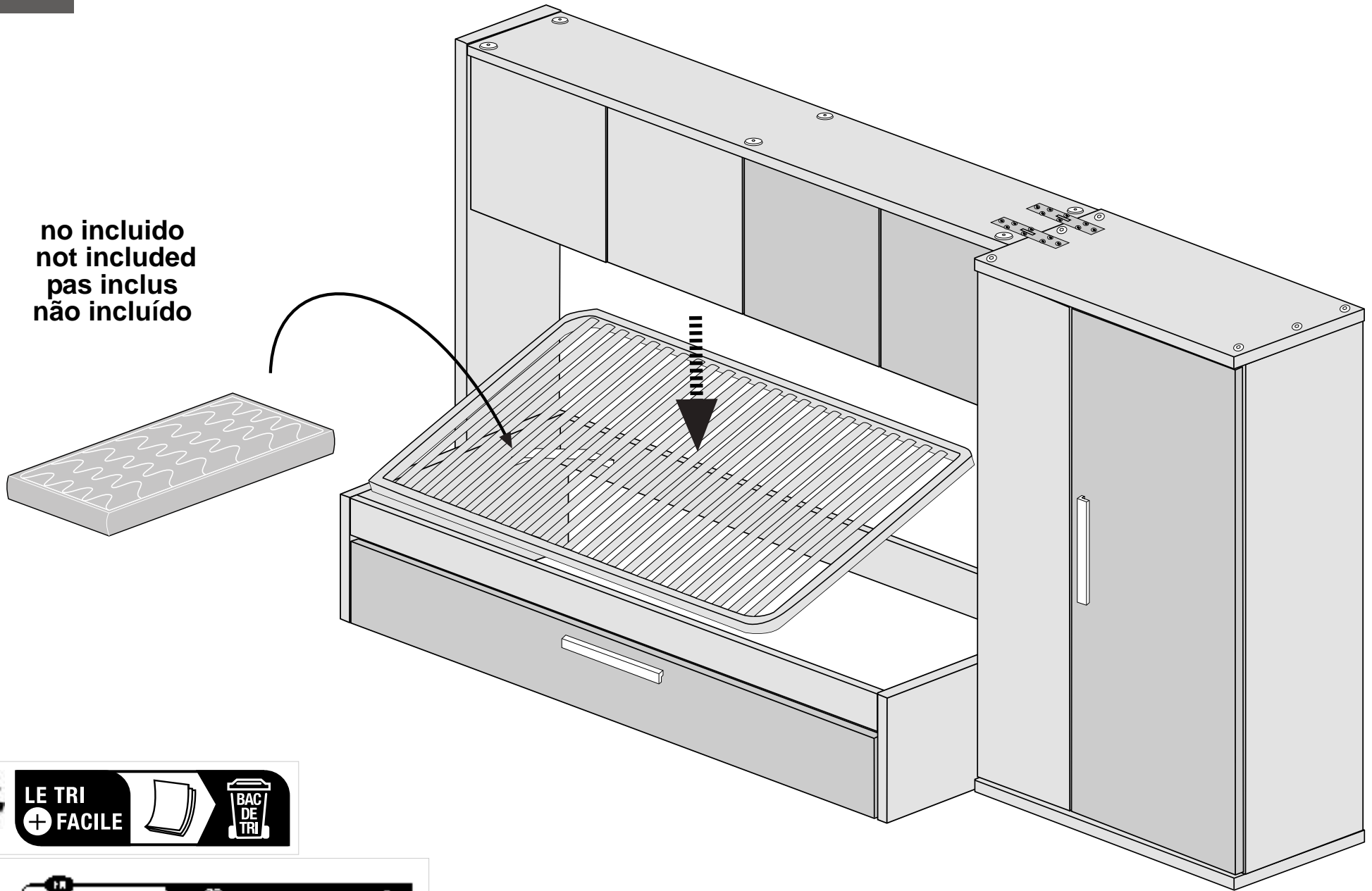

LE TRI
+ FACILE



TR

Primeru je
dohar eu recyclicar.



Minis d'Associacjonez domesticas, y